



The Sound That Will *Move* You

SM6BT

6.5-INCH 2-WAY BI-AMPLIFIED
PROFESSIONAL STUDIO MONITOR



www.earthquakesound.com

Table of Contents

Safety Instructions.....	3–4
Introduction.....	5
Amplifier Features.....	6–8
Placing Your SM6BT Monitors.....	8–9
Connecting & Bluetooth® Pairing.....	10
Specifications.....	11
Troubleshooting.....	12–13
Input Notes & Frequency Response.....	13
Warranty Guidelines.....	14–15



The Sound That Will Move You

Earthquake Sound Corporation
2727 McCone Avenue
Hayward, CA 94545
Tel: 510-732-1000
Fax: 510-732-1095

Customer Support
tech@earthquakesound.com
Tel: 800-576-7944
Fax: 510-732-1095

© 2025 Earthquake Sound Corporation. All rights reserved.

This document should not be construed as a commitment on the part of Earthquake Sound Corporation. The information is subject to change without notice. Earthquake Sound Corporation assumes no responsibility for errors that may appear within this document.

This device complies with Part 15 of the FCC Rules and ICES-003 for Canada. Operation is subjected to the following two conditions: (1) this device may not cause harmful interference, and (2) this device must accept any interference received, including interference that may cause undesired operation. CAN ICES-3 (B)/NMB-3(B)

FCC ID: 2A7SX-SM6BT

Safety Instructions

Safety First

This documentation contains general safety, installation, and operating instructions for the SM6BT studio monitors. It is important to read this user's manual before attempting to use this product. Pay particular attention to the safety instructions.

Symbols Explained:



Appears on the component to indicate the presence of uninsulated, dangerous voltage inside the enclosure – voltage that may be sufficient to constitute a risk of shock.

CAUTION

Calls attention to a procedure, practice, condition or the like that, if not correctly performed or adhered to, could result in injury or death.

WARNING

Calls attention to a procedure, practice, condition or the like that, if not correctly performed or adhered to, could result in damage to or destruction of part or all of the product.

Note:

This calls attention to any information that is essential to highlight.

This triangle, which appears on your component, alerts you to the presence of uninsulated, dangerous voltage inside the enclosure - voltage that may be sufficient to constitute a risk of shock.

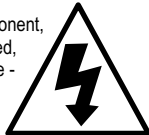

This triangle, which appears on your component, alerts you to important operating and maintenance instructions in this accompanying literature.



Unpacking System Components

- Keep the original carton and packing materials for future shipment or storage of your product/s.
- Check for any visual signs of damage. If you encounter any concealed damage, consult your Earthquake Sound dealer before proceeding with unit installation.
- Retain the sales receipt as it establishes the duration for the limited warranty and provides information for insurance purposes.

Safety Instructions Cont.

1. Read these instructions in their entirety.
2. Store this manual and packaging in a safe place.
3. Read all warnings.
4. Follow instructions (do not take shortcuts).
5. Do not use this apparatus near water.
6. Clean only with a dry cloth.
7. Do not block any ventilation openings. Install in accordance with the manufacturer's instructions.
8. Do not install near any heat sources such as radiators, heat registers, stoves, or other apparatuses that produce heat.
9. Do not defeat the safety purpose of the polarized or grounding-type plug. A polarized plug has two blades with one wider than the other. The grounding-type plug has two blades and a third grounding prong. The wide blade or the third prong is provided for your safety. If the provided plug does not fit into your outlet, consult an electrician for replacement of the obsolete outlet.
10. Protect the power cord from being walked on or pinched, particularly at plugs, convenience receptacles, and the point where they exit from the apparatus.
11. Only use attachments and accessories specified by the manufacturer.
12. Use only a compatible rack or cart for the final resting position.
13. Unplug this apparatus during lightning storm or when unused for a long period of time.
14. Refer all servicing to qualified service personnel. Servicing is required when the apparatus has been damaged in a way such as: power-supply cord or plug is damaged, liquid has been spilled or objects have fallen into the apparatus, the apparatus has been exposed to rain or moisture, does not operate normally, or has been dropped.
15. To reduce the risk of fire or electric shock, do not expose this apparatus to rain or moisture.

Introduction

Where precision meets power, and every detail of your music comes to life, experience audio bliss with the new SM6BT Professional Studio Monitor from Earthquake Sound. This 2-way monitor speaker is designed for high-resolution audio and built from the ground up with high-quality components to ensure an exceptional listening experience.

At the heart of the SM6BT is a custom 2-inch wide band ribbon driver that captures the subtlest waveforms and the highest frequencies, allowing you to hear every nuance in your music. Its unique design allows for excellent dispersion over a wide area compared to traditional tweeter designs, resulting in a wider sweet spot with focused vertical dispersion while minimizing surface reflections.

In addition, the rigid yet light-moving mass of a 6.5-inch woven carbon fiber cone woofer ensures minimal distortion, delivering accurate mid/low frequency reproduction down to 35Hz with a punchy bass response. With a total of 230W of Class AB power, bi-amplified to drive both the woofer and ribbon tweeter, the SM6BT stands as one of the most potent monitor speakers in its category.

The SM6BT is not only a powerhouse when it comes to performance but also offers modern convenience from built-in Bluetooth. With a wireless range of up to 100 meters, users can wirelessly stream their favorite audio to the SM6BT via Bluetooth v5.3 technology with True Wireless Stereo (TWS) pairing. Balanced and unbalanced inputs and subwoofer output are also provided for ultimate flexibility for a broad range of audio setups.

Whether you're an audio professional or a passionate music enthusiast, the Earthquake Sound SM6BT is a testament to precision engineering and an unwavering commitment to audio excellence. Elevate your listening experience and uncover new dimensions in your music with the SM6BT.

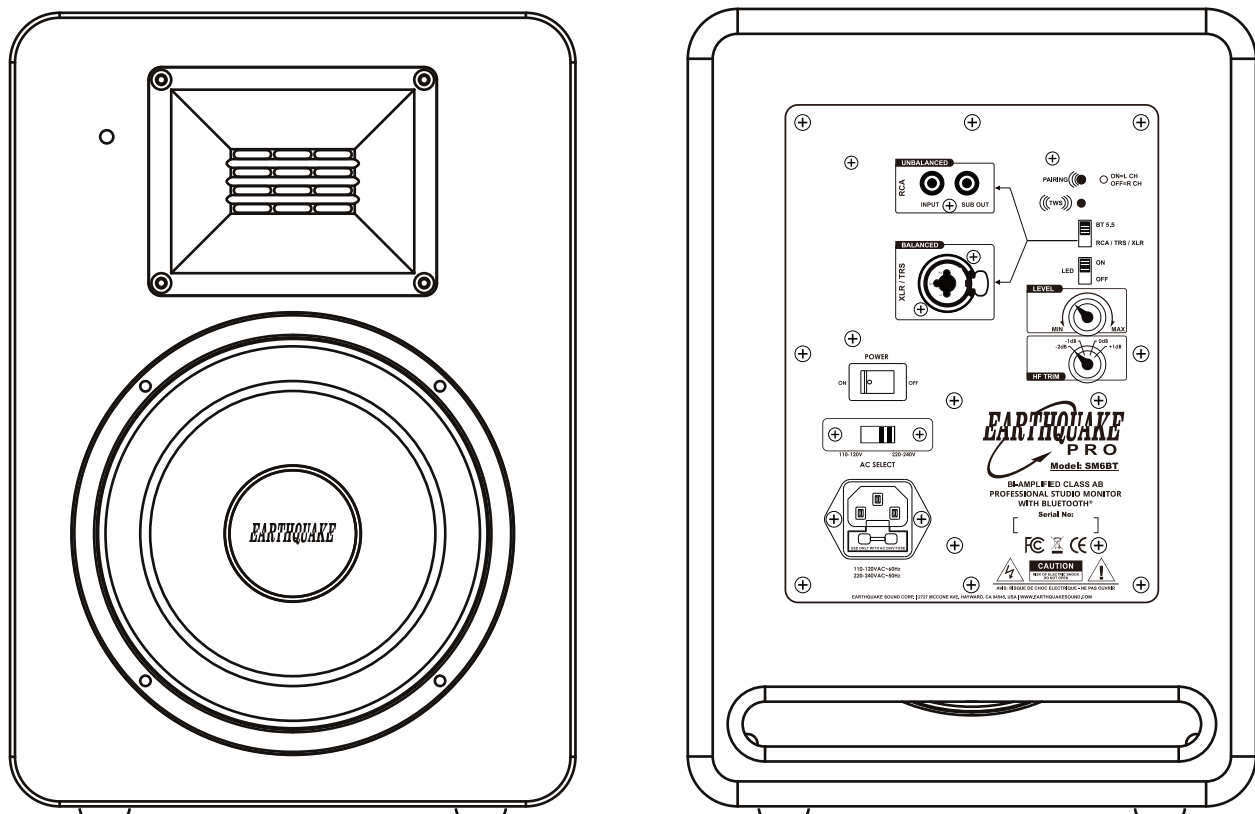

Amplifier Features

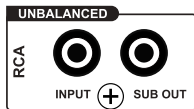
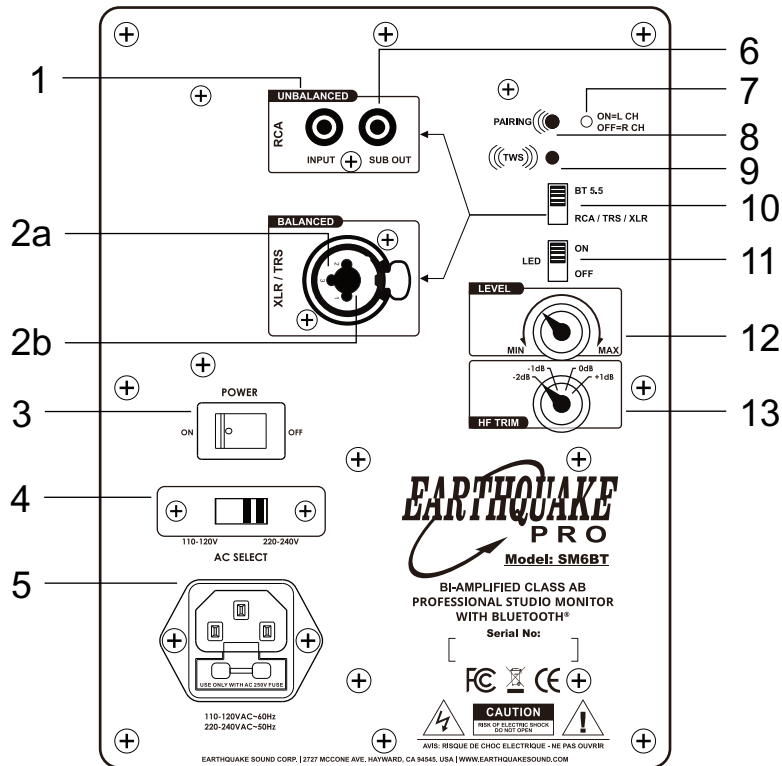

1. Unbalanced RCA Input

RCA input for connecting the SM6BT monitor to your TV, computer, DJ equipment, mobile device, etc.

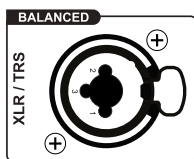

2a. Balanced XLR Input

10kOhm balanced XLR input for connecting the SM6BT monitor to your audio interface or mixer.

2b. Balanced 1/4-Inch TRS Input

10kOhm balanced TRS input for connecting the SM6BT monitor to your audio interface or mixer. For best result, be sure to use a balanced 1/4-inch TRS phone plug.

NOTE:

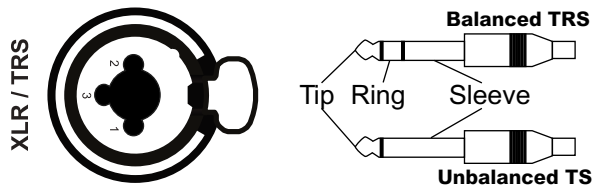

Pin 1: Sleeve (Shield) = Ground (cable shield)

Pin 2: Tip = Positive/Red/Hot

Pin 3: Ring = Negative/Black/Cold

WARNING

CONNECT ONLY ONE INPUT SOURCE AT A TIME.

Amplifier Features Cont.

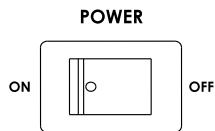

3. Main Power Switch

This switch controls the AC power going to the SM6BT monitor. We suggest keeping the switch in the OFF position when the monitor is not being used for an extended period of time.

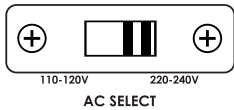

4. 110V/220V Selector Switch

The SM6BT monitors can operate in a 110-120V or 220-240V environment. Simply slide the selector to the required power input setting and replace the fuse to the proper rating **prior to** connecting the monitors to a power source.



USE OF IMPROPER VOLTAGE MAY RESULT IN HAZARDOUS CONDITIONS AND/OR DAMAGE TO THE MONITOR COMPONENTS THAT ARE NOT COVERED BY THE FACTORY WARRANTY.



FOR YOUR SAFETY, PLEASE MAKE SURE THAT THE MONITOR IS NOT CONNECTED TO ANY POWER SOURCE PRIOR TO ACCESSING THE AC SELECTOR AND FUSE COMPARTMENT.

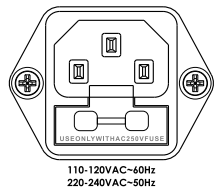

5. AC Power Inlet with Fuse Holder

This AC line connector is fused to protect the amplifier from unwanted power surges. Be sure to use the proper fuse rating when replacing the existing fuse:

ø5 x 20mm 2A/250V UL/VDE slow blow tube fuse

To access the fuse compartment, simply unplug the power cable from the monitor, place a flat-head screw driver in the small notch and pry it open as illustrated.

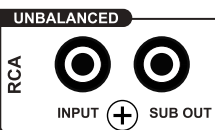
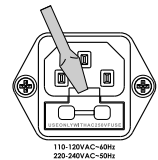

6. Subwoofer Output

This unbalanced RCA output is used for providing signal to a powered subwoofer if needed.

○ ON=L CH
OFF=R CH

● ON=L CH
OFF=R CH

7. TWS Status LED Indicator

This LED is the True Wireless Stereo (TWS) master speaker and slave speaker indicator. When TWS pairing succeeds, the software automatically assigns the master and slave speakers. Usually, the master speaker is the left channel, and the slave speaker is the right channel.



8. Pairing Button

This button is used to connect the SM6BT to a mobile device. See page #10 for pairing procedure.

Amplifier Features Cont.



9. True Wireless Stereo (TWS)

This button is used to put the two SM6BT monitors in True Wireless Stereo pairing mode. See page #10 for TWS pairing procedure.

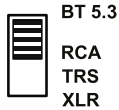

10. Input Selector Switch

This is a 2-way selector switch that allows you to select between input methods. Sliding the switch up enables Bluetooth® and sliding it down enables the unbalanced or balanced inputs. When using the Bluetooth® input, make sure that this switch is set to the correct position before pairing to any Bluetooth® enabled devices.



11. LED ON/OFF Selector Switch

This is a 2-way selector switch allows for the user to turn the front mounted LED indicator light on or off.

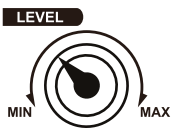

12. Level Adjustment Knob

This knob controls the monitor's input sensitivity. Typically, you would want to set the knob to the maximum setting (+6dB), adjust the source's output level and then use the level knob to match the left and right monitors.

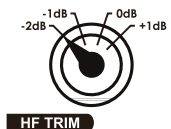

13. HF Trim Knob

This high frequency adjustment knob is factory set at 0dB or flat. Adjust this knob accordingly to tailor the sound to your listening preferences.

SM6BT Monitor Placement

The placement of your SM6BT monitors is one of the most crucial steps to ensure that they perform at their best.

Studio/Stereo Application

Earthquake suggests placing the monitors within the front 1/3 of the room, about 3 to 5 feet away from each other and directed at a 60 degree angle towards your listening position.

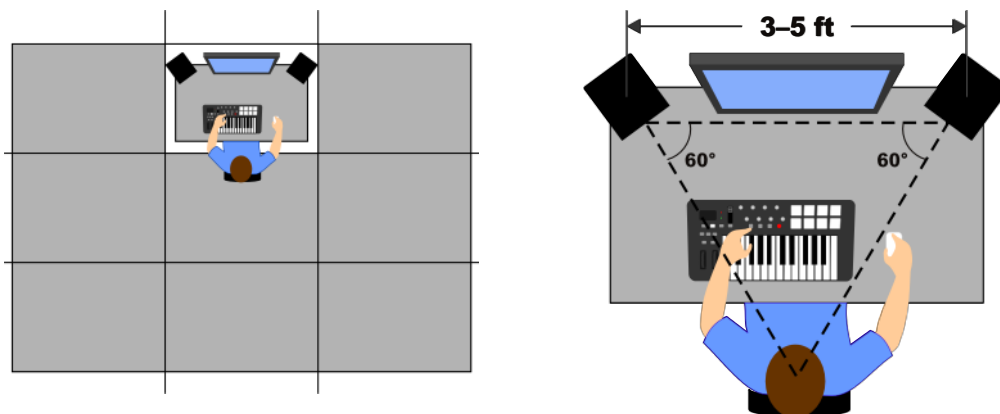

SM6BT Monitor Placement Cont.

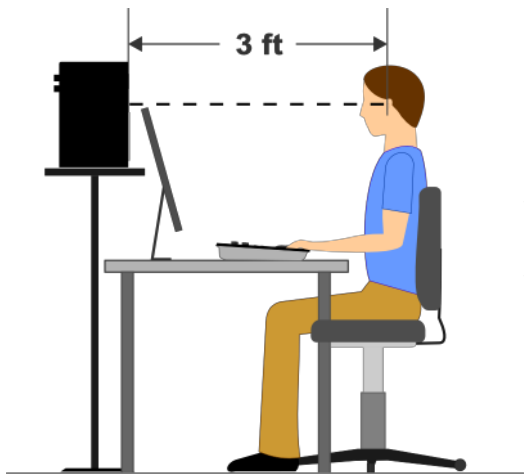

Earthquake Sound suggests placing the SM6BT monitors at least 3 feet away to reduce distortion by reflection and diffraction. Because high frequencies are primarily directional, to achieve the most precise monitoring, the SM6BTs should be placed so that the ribbon tweeters are approximately the same height as your ears when seated at your listening position. To attain the optimized performance, you may angle the monitors to aim towards your ears when in your listening position.

Avoid placing large objects near the monitors and listening position.

SM6BT Monitor Surround Sound Application

Begin by placing the center channel monitor right before your listening position. Then place the front left and right monitors at an equal distance and about 25 to 30-degree angle from the center. The three front monitors (left, center, and right) should form a slight arc, as shown below. Continue placing the rear monitors at an equal distance from the listening position and angled about 90 to 110 degrees from the center, as illustrated below.

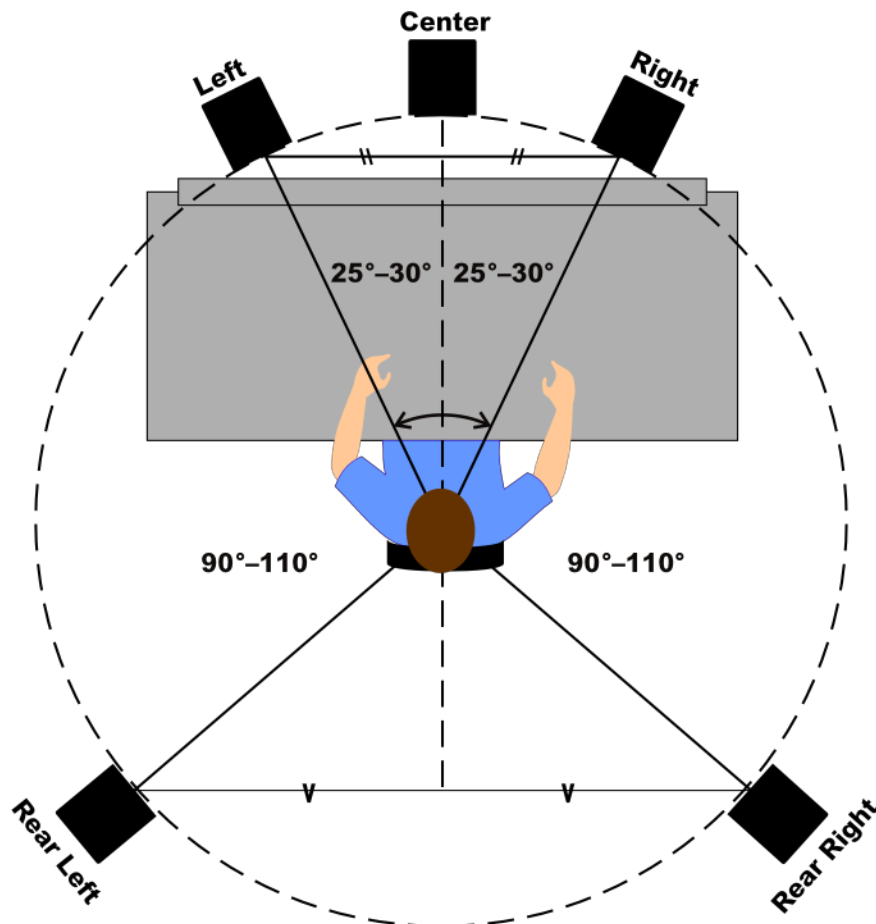

Connecting Your SM6BT Monitor

For convenience, the SM6BT provides users with three different types of wired input connections as well as Bluetooth® wireless with True Wireless Stereo (TWS) pairing. Use the information below to select the correct input method for your AV source equipment, whether for everyday general listening or professional studio-level applications. Set up your system in a way that best suits your listening needs and make sure that the input selector is in the correct position prior to use.

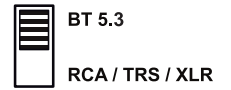

Unbalanced RCA Input

The unbalanced RCA input is one of the most widely used inputs for home audio setups for driving signal from AV equipment. When possible, use high-quality cables of the shortest length to help prevent noise or interference from degrading the sound.

Balanced XLR & TRS Input

Widely used in professional audio applications, balanced connections carry audio signals over cable runs that generally extend further than those in home audio and are likely to be exposed to potential sources of electromagnetic interference or EMI. The fully balanced XLR/TRS combo jack input can be utilized when the distance between the SM6BT monitor and the audio source is excessive and susceptible to EMI. This combo input is a true balanced input with both conductors isolated relative to ground. Although widely used by audio professionals, these connectors are not limited to everyday users.

Bluetooth® Pairing & Connecting



Connecting Bluetooth-Enabled Devices

Press and hold down the PAIRING button of the master SM6BT monitor speaker for more than 2 seconds (LED fast flash), and the mobile device can be paired with the master speaker. You will find "SM6BT" in the list of available Bluetooth® enabled devices to connect. Once the connection is successful, the LED will stop blinking, and you can hear the prompt tone of "successful pairing."

True Wireless Stereo (TWS) Pairing

Press and hold down the TWS button on the master and slave SM6BT monitor speakers for more than 2 seconds. You will hear the "TWS PAIRING" prompt tone. Wait a while, and the monitors will pair with TWS mode (and sound the TWS CONTROL tone). Master SM6BT monitor (left channel) rear amp LED ON, slave SM6BT monitor (right channel) rear amp LED OFF.

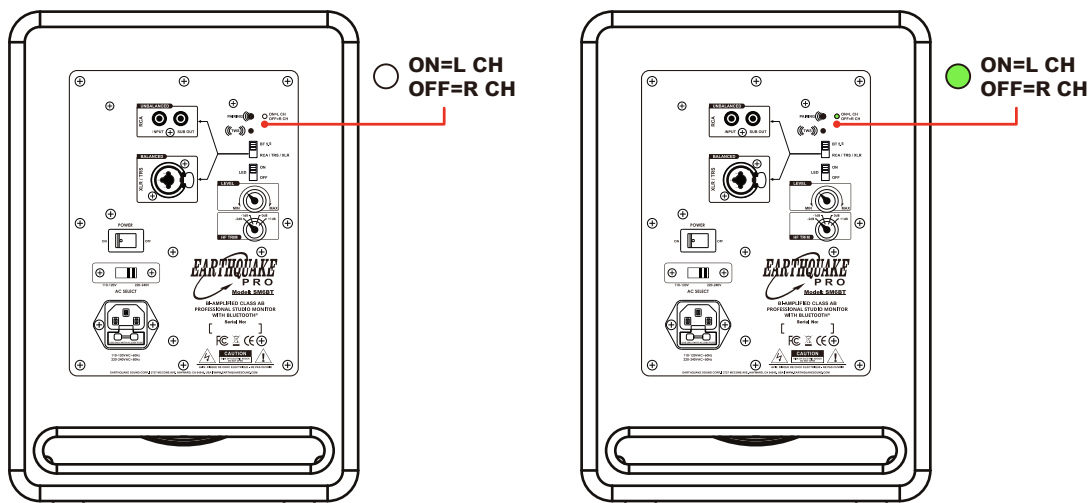

SM6BT Specifications

Configuration	2-Way
System Type	Bi-amplified Class AB Architecture
Enclosure Type	Rear-Firing Bass Reflex
HF Driver	2 Wide Band Ribbon Tweeter
LF Driver	6.5 Carbon Fiber Cone Woofer
Frequency Range (-10dB)	35Hz–40kHz
Crossover Frequency	2.8kHz @ 12dB/Oct
Power Rating (HF / LF)	80 Watts / 150 Watts
Peak SPL	108dB
Subsonic Filter	25Hz
Inputs	10 kOhm Balanced TRS/XLR Combo 10 kOhm Unbalanced RCA Bluetooth® v5.3
Outputs	RCA Sub Out
Controls	System Level Control (-80dB to +6dB) HF Level Control (-2dB, 1dB, 0, +1dB)
Supported Audio Formats	aptX™, aptX™ HD, aptX™ Adaptive,FLAC, FastStream, AAC, AAX+, MP3, SBC
Cabinet Material	3/4 (20mm) MDF
Cabinet Finish	Matte Black Finish
Dimensions H x W x D With feet, grille, and amplifier	12.75 x 9 x 11.5 324mm x 228mm x 292mm
Fuse Rating	ø5x20mm 2A/250V UL/VDE slow blow tube

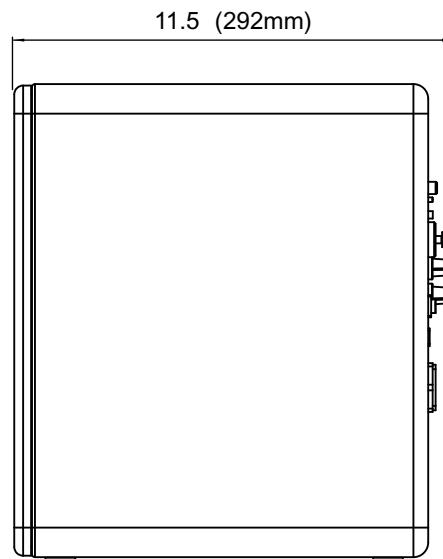
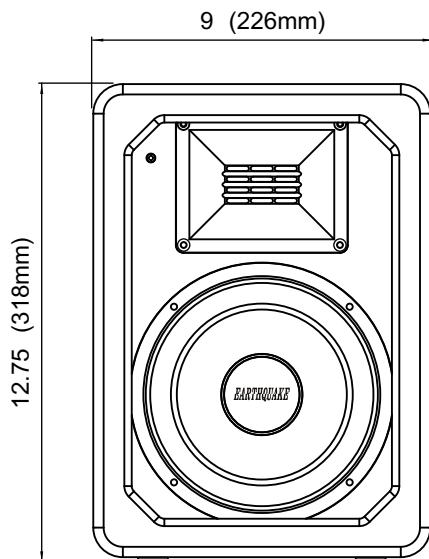

Troubleshooting The SM6BT Monitor

The Front LED Does Not Light Up

- Inspect the power cable. Never use one that has been altered in any way.
- Verify the AC power outlet is active and supplying the appropriate AC voltage.
- Verify the monitor's AC selector is set to the proper setting with the correct fuse installed (refer to page 7 for fuse rating and how to access the fuse compartment). Make sure that the fuse is not blown.
- Verify that the power cord is securely plugged into the unit and the power AC outlet.
- Check that the monitor's POWER switch is ON.
- Check to ensure the LED ON/OFF selector is in the correct position.
- If the fuse(s) blow once the monitor is switched on, please contact Earthquake Sound Technical Support at (1-510-732-1000 or tech@earthquakesound.com).

The Front LED Lights Up But There Is No Sound

- Perform the troubleshooting steps above before proceeding with the next steps.
- Verify that all devices plugged into the same AC outlet are still working.
- Make sure that the signal source (e.g., mixing console, DJ workstation, etc.) is at a level that can properly send a signal to the monitor(s).
- Make sure the VOLUME knob (system gain potentiometer) is turned fully clockwise to +6dB.
- Ensure the audio source cable is firmly plugged into both the source output and the monitor input.
- If operating two monitors and this problem only occurs on one of the units, exchange the audio input cable from the non-working unit to the working one to determine where the problem lies (the monitor, the cable, or elsewhere).
- If the problem persists, please contact Earthquake Sound technical service.

The Monitor Suddenly Stops Working

- Turn the SM6BT monitor off.
- Perform the troubleshooting steps above before proceeding with the next steps.
- Carefully check if the amplifier's back plate is hot. It is possible that the protection circuitry was triggered and shut down because it ran at its highest power output for an extended time. Turn the monitor power off and keep it off for at least 30 minutes to allow the amplifier to cool down before turning it back on.
- Increase the volume to check for normal operation.

Troubleshooting The SM6BT Monitor Cont.

- If the monitor is still unresponsive, please contact Earthquake Sound technical service.

The Sound Quality Changes

- Perform the previous troubleshooting steps before proceeding with the next steps.
- Disconnect the signal cable at the monitor's input. With the monitor powered on, position your ear close to each driver (tweeter/woofer) and listen for any noise (i.e., a slight hiss or hum). If no noise of any kind is heard, one or more of the drivers (woofer, tweeter, or both) may be faulty. It is also possible that the problem lies elsewhere in the electronics.
- Reconnect the signal cable to the monitor's input and play some non-distorted source material at low volume. Carefully cover the tweeter to block the sound. If the woofer sounds distorted or has no sound, it may have been internally disconnected or needs replacing.
- Play the same non-distorted source material but cover the woofer instead so that the tweeter is mainly heard. If the sound from the tweeter is not of clear tonal quality or if there is no sound at all, then the tweeter may have been internally disconnected or needs replacing.

The Monitor Produces Hisses, Hums, or Other Loud Noises

- Ensure that the power cord is firmly plugged into the monitor.
- Inspect the connection between the signal source and the monitor. Note that the SM6BT's XLR and 1/4 TRS connectors are entirely balanced. If you connect an unbalanced signal to the monitor, use Pin 2 for the signal and tie Pin 1 and 3 together at the source end.
- Make sure the AC mains match the operating voltage requirements.
- Ensure all audio equipment in your system uses the same ground point. Avoid connecting dimmers, neon signs, TV screens, and computer monitors to the same AC output of your audio equipment.

Input Notes

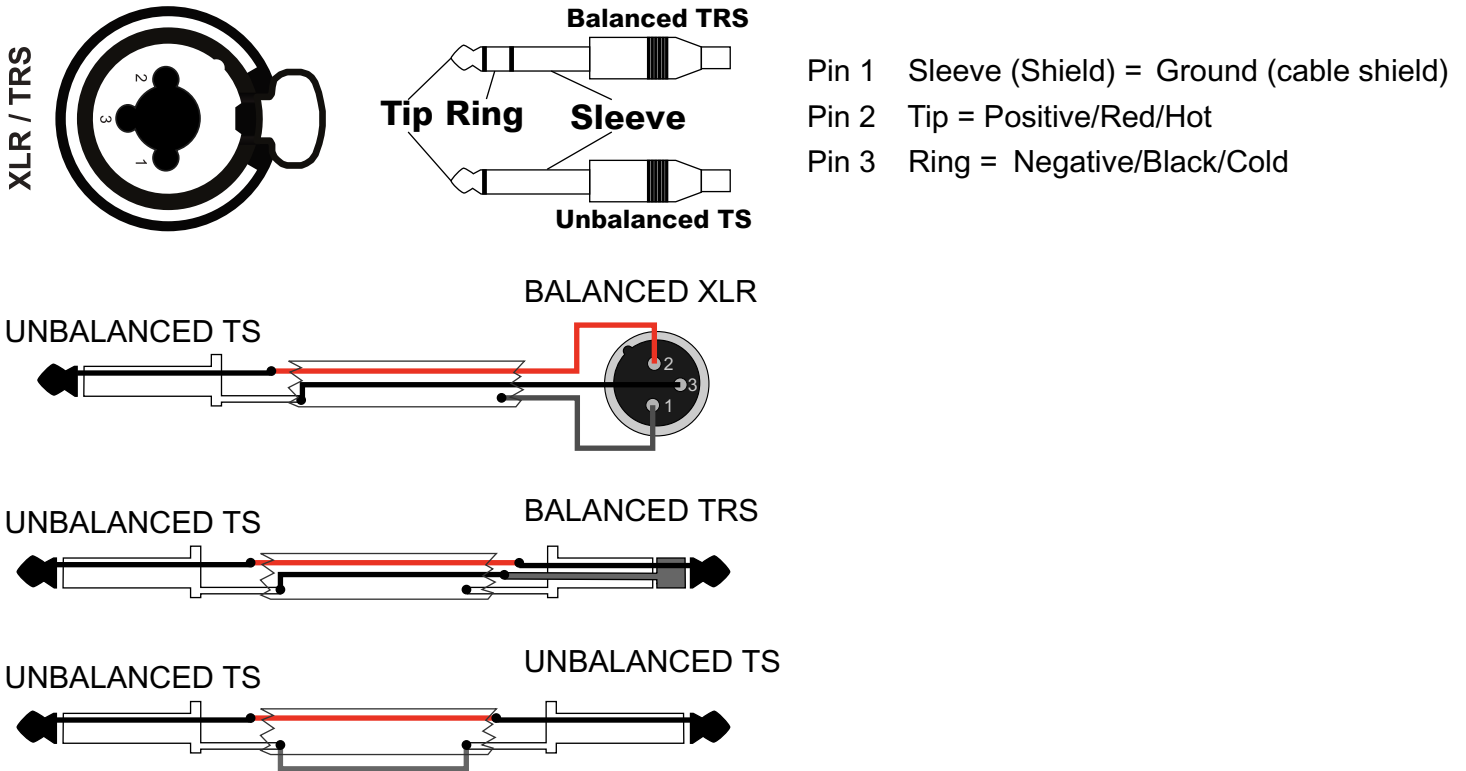

Frequency Response

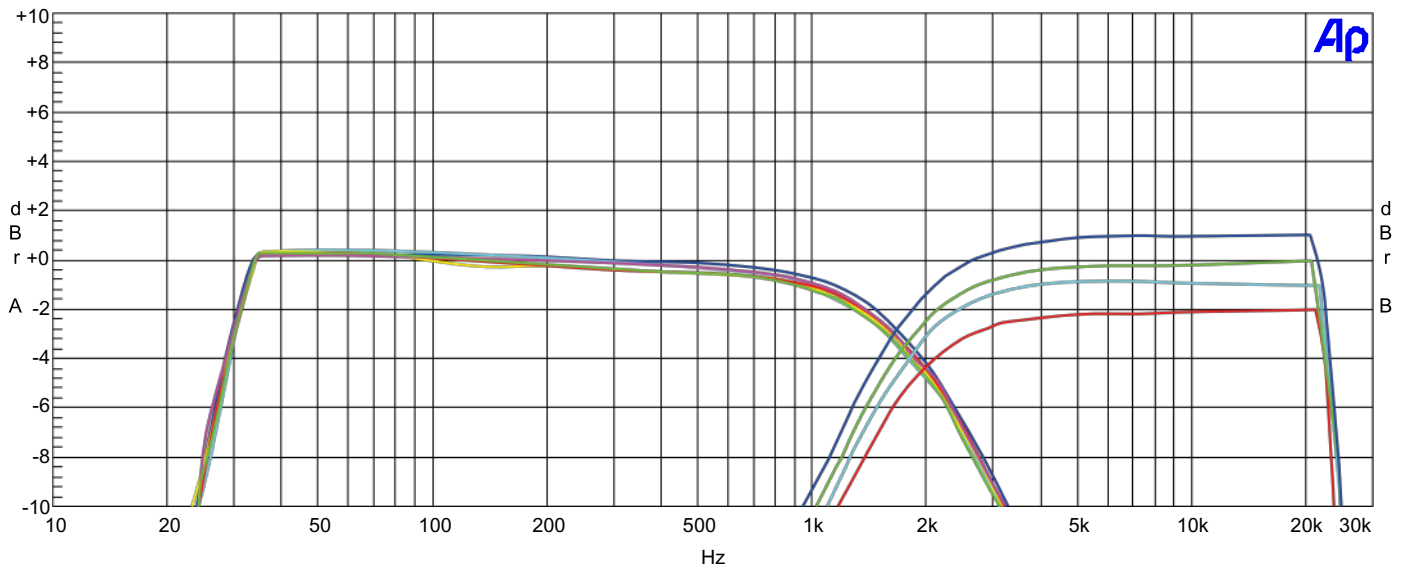

Warranty Information

5 Year Limited Warranty Information

Earthquake Sound warrants the original purchaser that all Factory Sealed New Audio products be free from defects in material and workmanship, under normal and proper use, for a period of **five (5) year from the date of purchase** (as shown on the original sales receipt with serial number attached/written on it). The one (1) year warranty period is valid only if the product is properly installed by an Earthquake Sound authorized party and the warranty registration card is properly filled out and sent to Earthquake Sound Corporation. If the product is installed by a non-authorized party, a thirty (30) day warranty period applies.

(A) Five (5) year limited warranty guidelines:

- **First Year:** Earthquake pays for labor, parts and ground freight (US Mainland only, not including Alaska and Hawaii.) Shipping to us is not covered.
- **Second, Third, Fourth, & Fifth Year:** Earthquake pays labor only. Customer must pay for parts and freight both ways.

(B) Warning:

- Products (sent for repair) that are tested by Earthquake technicians and deemed to have no problem(s) will not be covered by the limited warranty. Customer will be charged a minimum of one (1) hour of labor (at ongoing rate) plus the shipping charges back to the customer.
- Each product sent in for repair must be packaged in its original packaging. Otherwise, repackaging charges will apply in addition to the labor, parts, and shipping charges.

(C) Earthquake agrees to repair or replace - at our discretion - all such defective products/parts subject to the following provisions:

- Defective products/parts have not been altered or repaired by other than an Earthquake factory approved technician.
- Products/parts are not subjected to negligence, misuse, accident, or damaged by improper line voltage.
- Products/parts were used with incompatible products.
- The serial number or any part of the product has been altered, defaced, or removed.
- Products/parts have been used in any way that is contrary to Earthquake's written instructions.

(D) Warranty Limitations:

Earthquake warranty does not cover products that have been modified or abused, including but not limited to the following:

- Damage due to misuse, abuse, or improper cleaning materials/methods.
- Bent speaker frame, broken connectors, hole(s) in speaker cone, hole(s) in surround or dust cap, and burnt speaker voice coil.
- Fading and/or deterioration of speaker components & finish due to improper exposure to elements.
- Burnt tracers found on the printed circuit boards (PCB).
- Product/part damaged due to poor packaging or abusive shipping conditions.
- Subsequent damage to other products.

A warranty claim will not be valid if the warranty registration card is not properly filled & returned to Earthquake with a copy of the sales invoice.

(E) Service Request:

To receive product(s) service, contact Earthquake Sound's service department at (510) 732-1000 or tech@earthquakesound.com and request an RMA (Return Material Authorization) number as item(s) shipped without a valid RMA number will be refused. Make sure you provide us with your complete and correct shipping address, a valid daytime phone number, and a brief description of the problem you are

Warranty Information Cont.

experiencing with the product. In most cases, our technicians might be able to resolve the problem over the phone or via e-mail, thus eliminating the need to ship the product.

(F) Shipping Instructions:

Product(s) must be packaged inside its original protective box(es) to minimize transportation damage. Shipper claims regarding items damaged in transit must be presented to carrier. Earthquake Sound Corporation reserves the right to refuse improperly packaged product(s). A copy of the original sales receipt must accompany the product(s) returned for service. Ship the product(s) to:

Earthquake Sound Corporation. 2727 McCone Avenue. Hayward, CA 94545

The customer is responsible for the cost of shipping the product(s) to Earthquake Sound Corporation

(G) Disputes Resolution:

All disputes - between clients and Earthquake Sound Corporation - resulting from the one (1) year limited warranty policy must be resolved according to the laws & regulations of the county of Alameda, California.



The Sound That Will Move You

Earthquake Sound reserves the right to amend details of the specifications without notice.

Copyright © Earthquake Sound Corporation

Earthquake Sound Corporation • 2727 McCone Avenue Hayward CA, 94545

Phone: 510-732-1000 | www.earthquakesound.com