

ROCK-ON Series

Limestone & Granite Series

User Manual



The Sound That Will Move You

ROCK-ON

Limestone-82 Speaker

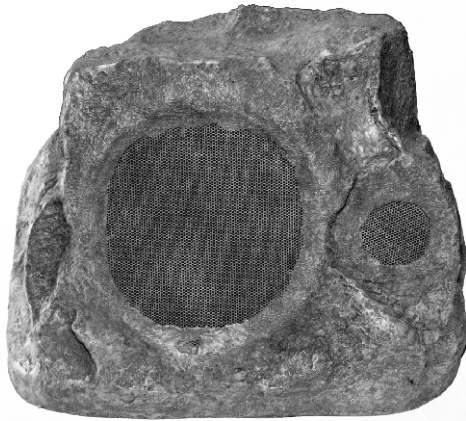

Granite-52 Speaker



Limestone-10D Subwoofer



Granite-10 & Granite-10D
Subwoofer

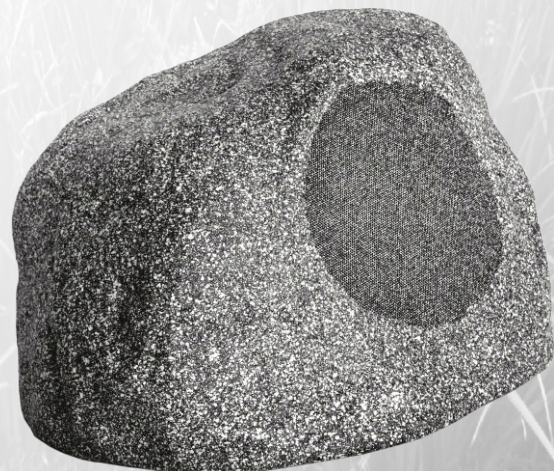

EARTHQUAKE EARTHQUAKE SOUND

The Sound That Will Move You

Earthquake Sound Corporation
2727 McCone Avenue
Hayward, CA 94545
Tel: 510-732-1000
Fax: 510-732-1095

Customer Support
tech@earthquakesound.com
Tel: 800-576-7944
Fax: 510-732-1095

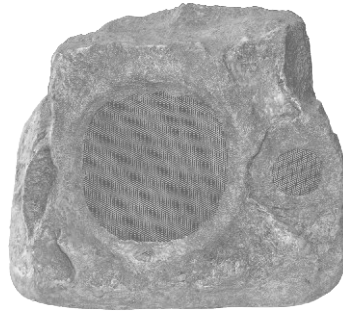

ROCK-ON
Limestone Series

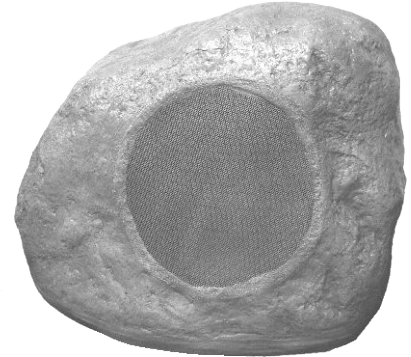

Limestone-10D



Granite-52

ROCK-ON
Granite Series



Granite-10 & 10D

Table of Contents

About Earthquake Sound.....	3
Specifications	4
Features	5
System Designs	6-7
Unpacking & Safety	8-9
Warranty.....	10

Symbols Explained:

CAUTION

Calls attention to a procedure, practice, condition or the like that, if not correctly performed or adhered to, could result in injury or death.



Appears on the component to indicate the presence of uninsulated, dangerous voltage inside the enclosure – voltage that may be sufficient to constitute a risk of shock.

WARNING

Calls attention to a procedure, practice, condition or the like that, if not correctly performed or adhered to, could result in damage to or destruction of part or all of the product.

Note:

Calls attention to information that is essential to highlight.

This document should not be construed as a commitment on the part of Earthquake Sound Corporation. The information is subject to change without notice. Earthquake Sound Corporation assumes no responsibility for errors that may appear within this document.

About Earthquake Sound Corporation

Earthquake Sound Corporation was founded in 1984, by Joseph Y. Sahyoun - an engineer and a well respected developer of audio technologies. Mr. Sahyoun's infatuation with audio, combined with his relentless pursuit of perfection and his love for music drove him to excel Earthquake Sound to become a leader in this industry.

For over 28 years, Earthquake Sound has been manufacturing a wide range of audio products that have impressed the audiophile communities throughout the world. Relentless pursuit of perfection, full attention to details and true dedication drove Earthquake Designers and Engineers to develop advanced products to meet and exceed consumers' needs and expectations.

All across the board, industry officials were as impressed: Earthquake Sound was selected the winner of over 20 prestigious awards based on sound quality, performance, value and features. The Consumer Electronics Association - CEA- and numerous well known publications have awarded Earthquake Sound with Design & Engineering Awards. Additionally, Earthquake Sound has been granted multiple patents by the United States Patent Office - USPO- for designs that have revolutionized audio reproduction.

Earthquake Sound is recognized throughout the world as an export leader in the industry: for this reason, the United States Secretary of Commerce - Gary Locke - honored Earthquake Sound with an Export Achievement Award for recent accomplishments in the global market place. Suffice to say, Earthquake Sound strives to provide consumers with the highest quality products at affordable prices, and without any compromise.

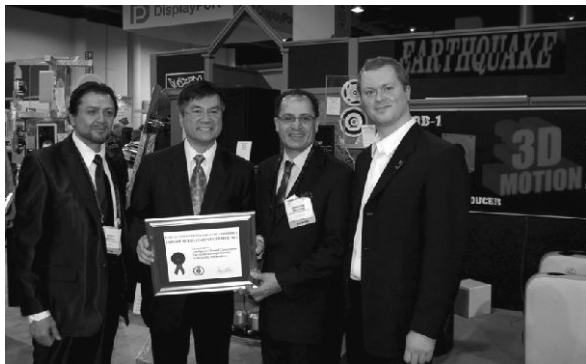

Left to right: Joseph Sahyoun, Secretary Gary Locke, Abraham Sahyoun and Thomas Mygind



Joseph Sahyoun

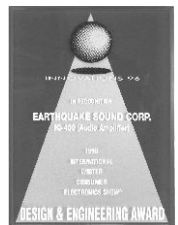
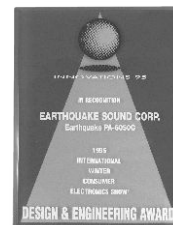

This owner's manual is designed to better acquaint you with the ROCK-ON speakers, and to guide you through the phases of system design and application. It is imperative that you read this manual in its entirety. EARTHQUAKE technicians and staff look forward to answer any questions you might have, please call (1-800-576-7944).

Introduction & Specifications

The Earthquake ROCK-ON outdoor speaker series is specifically designed to imitate rock appearance and easily blend in with any outdoor environment, it comes in a Limestone or a Granite finish. Made with UV treated, weather-resistant enclosure materials and durable epoxy resin construction, the ROCK-ON speakers can withstand the demanding outdoor elements.

The Limestone-82 is a full range speaker that integrates an 8 inch woofer and a 1 inch tweeter. It serves as a left or right speaker and has an amazing frequency response that is unmatched by any other rock speaker. It produces a crisp, clean, and accurate audiophile sound. The Granite-52 is also a full range 5 1/4" coaxial that serves as a left or right speaker.

The ROCK-ON subwoofers (Limestone-10D or Granite-10D) feature high power crossovers that reduce distortions and deliver pure sound that blends in with nature. These subwoofers bring true bass to your outdoor space, something that is greatly needed in today's rock speaker market. The port is "S" shaped that prevents water & moisture from getting trapped inside the structure. We have tested and retested our ROCK-ON speakers to ensure they are up to par with our reputable line of subs.

ROCK-ON outdoor speakers & subwoofers are the ideal choice for listening to music in the garden, by the pool, in the yard, or on the patio. Together, they turn any backyard into an entertainment center.

Specifications	Limestone-10D/ Granite-10 & 10D	Limestone-82	Granite-52
Frequency Response ($\pm 3\text{dB}$)	30Hz–100Hz	40Hz–21kHz	50Hz–21kHz
Power Handling	250W RMS / 500W Max	20–250 Watts	20–200 Watts
Impedance (ohms)	Dual 4-Ohm 10D / Single 8-Ohm 10	4 Ohm	4-Ohm
Sensitivity (1W@1M)	92dB	93dB	93dB
Woofer	10 in. (254 mm) Dual 2.5 in. diameter voice coil (10D) Single 2.5 in. diameter voice coil (10)	8 in. (204 mm)	5.25 in. (133 mm)
Tweeter	N/A	1 in. (25 mm) Mylar	.5 in. (13 mm) Mylar
Dimensions (HxWxD)	14 in. (356 mm) 18.5 in. (470 mm) 21 in. (534 mm)	11.5 in. (293 mm) 15 in. (381 mm) 11.75 in. (299 mm)	8.5 in. (216 mm) 8.5 in. (216 mm) 9 in. (229 mm)
Finish	Limestone or Granite	Limestone	Granite
Enclosure	15 mm epoxy resin	15 mm epoxy resin	15 mm epoxy resin

Limestone-10D / Granite-10/10D Subwoofer

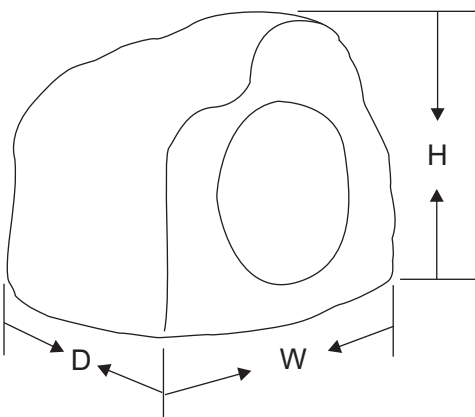

Limestone-82 Two-Way Speaker

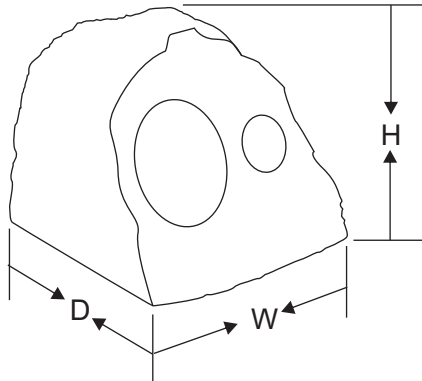

Granite-52 Coaxial Speaker

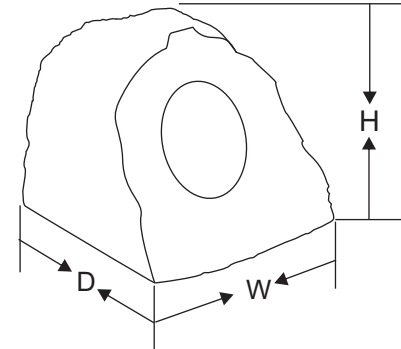

Features, Applications & More

Self-Cooling Design

Conventional outdoor subwoofers are sealed designs (sealed enclosure), they tend to build up internal heat; reaching temperature that exceeds 180 degrees. The side effects are devastating to the performance and life expectancy of the unit: poor performance, short lived drivers.

Earthquake designers and engineers integrated a clever, very creative ported design (10 & 10D subwoofers) that allow them to release the hot air. This port is an "S" shaped tube that has an opening in the lower back side, it extends upward inside the box thus preventing moisture and water from being trapped inside. In addition to keeping the subwoofer cool, this port adds 3dB boost to bass response (3dB = half the volume).

Moisture & Water Resistant

The biggest two downfalls of outdoor speakers are moisture and heat. Earthquake engineers resolved this problem by developing the world's first rubber spider: the injection molded rubber is shaped like a spider which is waterproof and durable under extreme weather conditions. The spider acts as a soft suspension yet serves as a moisture barrier.

The speaker is made with a waterproof polypropylene injection molded cone. The surround is made of butyl rubber and the front of the shaft is totally sealed from the back so no water/moisture will get trapped inside. Its design prevents moisture/water from getting inside the structure and damaging the unit.

"Built Like A Rock", They Feature:

- UV treated and weather-resistant enclosure material
- 15mm Epoxy resin durable construction
- Rock-like appearance and finish to easily blend in with any outdoor environment
- Completely sealed speaker with butyl rubber surrounds, poly cones and poly dust caps
- High power crossovers (for 10D subwoofers only)

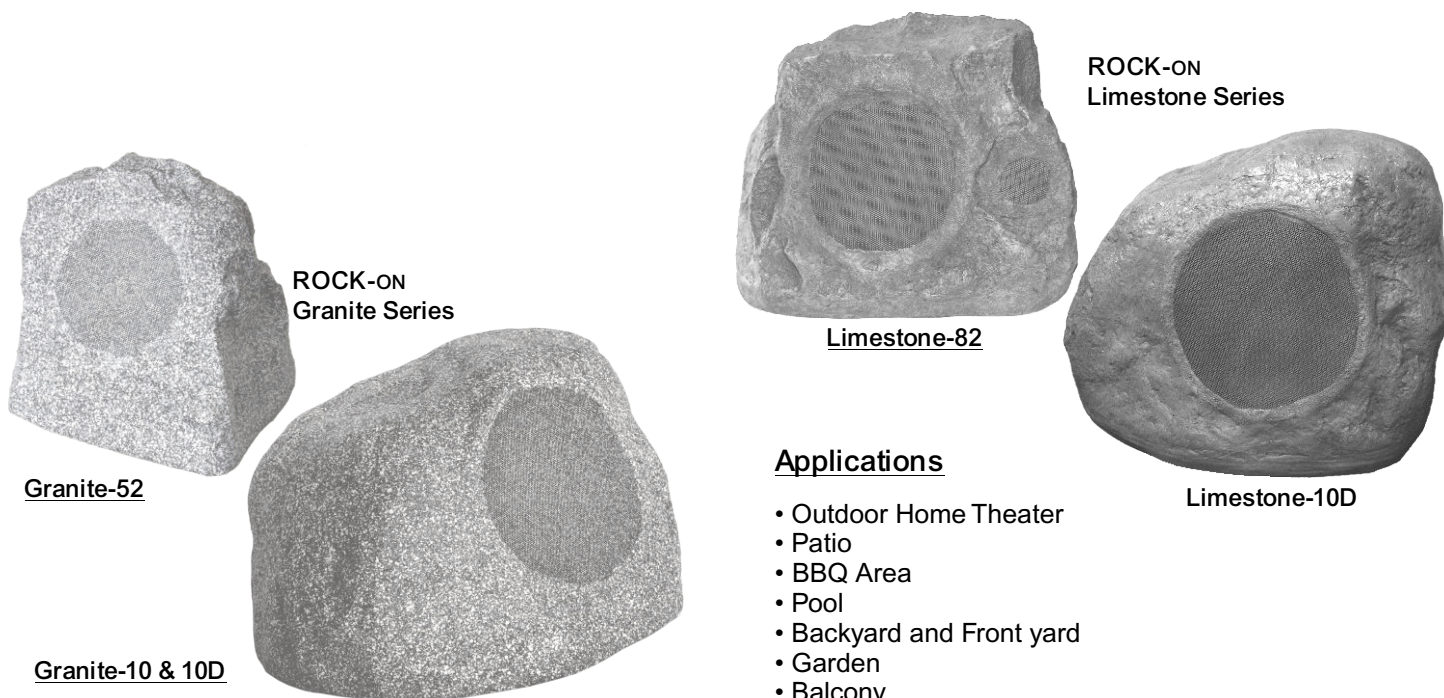

Applications

- Outdoor Home Theater
- Patio
- BBQ Area
- Pool
- Backyard and Front yard
- Garden
- Balcony

System Designs

Wiring two (2) Limestone-82 & one (1) XJ-300ST Zone Amplifier:



Wiring one (1) Limestone-10D & one (1) XJ-300ST Zone Amp:

CAUTION

WARNING

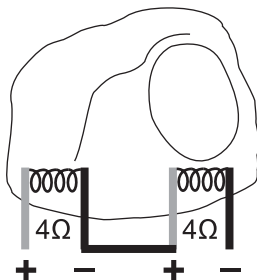

Both coils are wired in series for a total impedance of 8 ohms

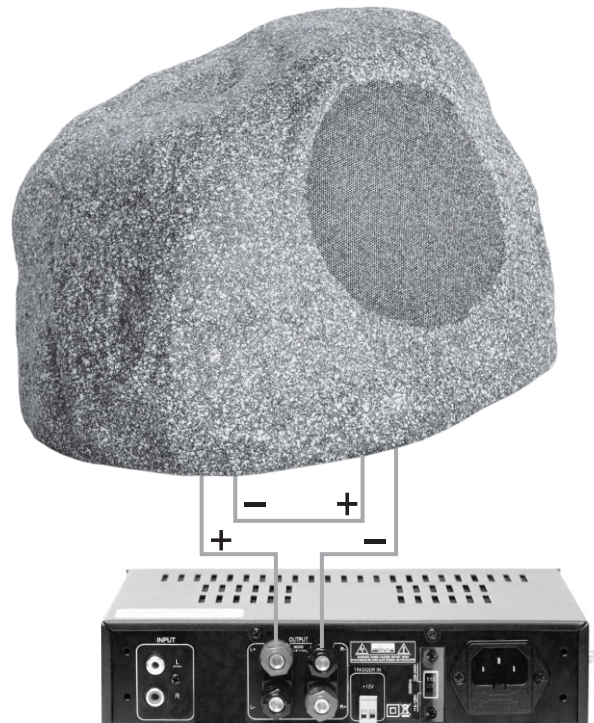

To simplify the wiring process, use Earthquake Sound's SWAT 2.4X Wireless Transceiver:

1. Connect the rock speakers and subwoofer to the XJ-300ST amplifier.
2. Connect the SWAT 2.4X Receiver to the XJ-300ST amplifier through the RCA inputs.
3. Connect the SWAT 2.4X Transmitter to any music player that has a mini jack or RCA output.

Note: Make sure both the Transmitter and the Receiver are connected to a power source, either through the DC power supply or the USB port.



System Designs: 2.1 System As Easy As 1,2,3...

ROCK-on Outdoor Speakers & XJ-300FR Zone Amplifier:

The extremely versatile XJ-300ST provides multiple channel options, mounting options and applications. The XJ-300ST 300 Watts amp is the perfect candidate to power up the ROCK-ON outdoor speakers.

The XJ-300ST Features:

- Auto signal/music sensing
- Class "J" stereo modular design
- Easy rack and wall mounting

The ROCK-on series includes a pair of Granite-52 OR Limestone-82 speakers and a Granite-10/10D OR a Limestone-10D subwoofer; a perfect match with the XJ-300ST amplifier.

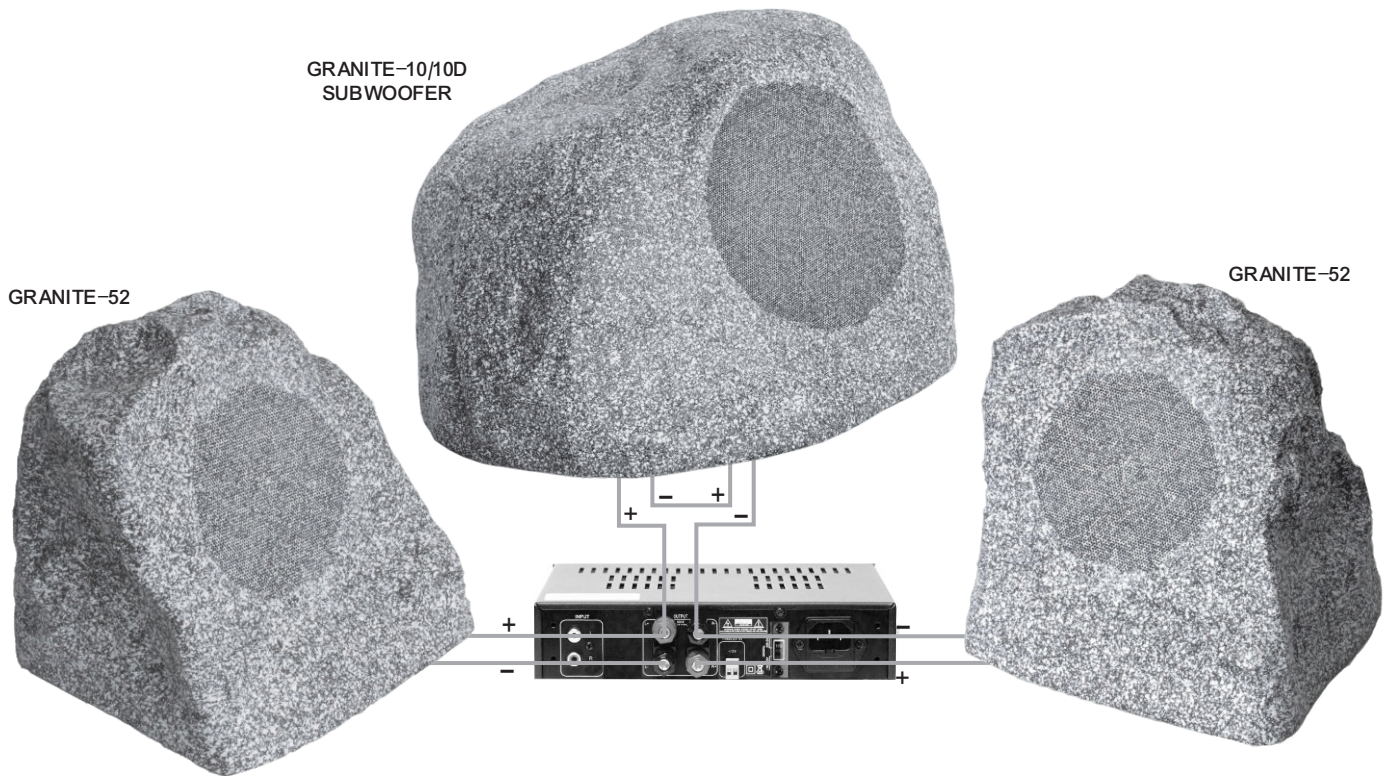

CAUTION WARNING

Earthquake Sound's XJ-300ST Stereo amplifier can be used to power up a ROCK-ON 2.1 system.

In tri-mode wiring, the user can connect the 2 channel stereo and the mono at the same time.

The subwoofer connection demonstrates a series wiring formula which has a load impedance of 8-Ohm.

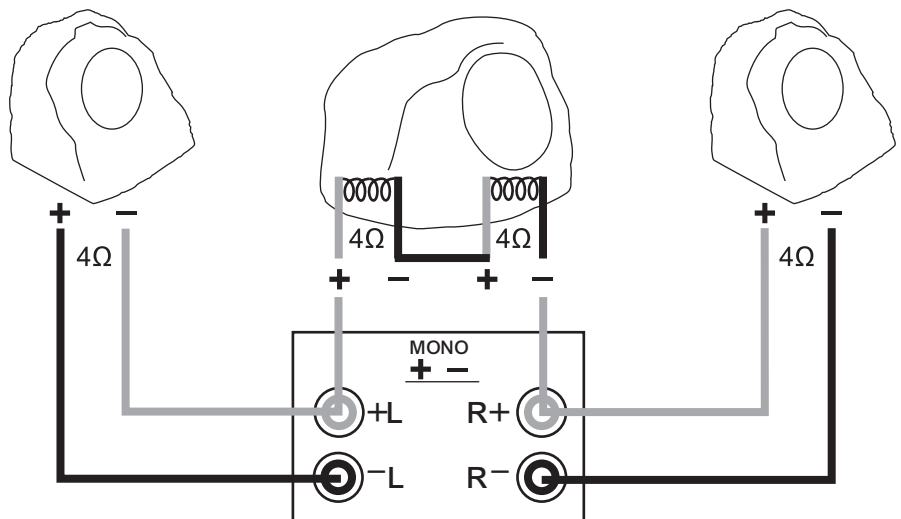

Unpacking & Wiring

Unpacking system components

- Keep the original carton and packing materials for future shipment or storage.
- Check for any visual signs of damage. If you encounter any concealed damage, consult your Earthquake Sound dealer before proceeding with unit installation.
- Retain the sales receipt as it established the duration of the limited warranty and provided information for insurance purposes.

System installation considerations

There are several factors to consider before installing Earthquake Sound's ROCK-on series.

- What are the intended listening zones?
- What system options and accessories might be required for features such as local sources, etc.?
- From where in each zone will the listener prefer to control the system? Where will the remote gains be located? Where will the speakers be located?
- Where will the source equipment be located?

Connection tips

- Keep all power cords away from all signal cables to prevent humming from induced noise.
- Choose reliable signal cables cords (Earthquake Sound also specializes in high-performance RCA cables and patches).
- All speaker wires that are ran through the walls should be twisted type to reduce potential hum noise pick up.
- It is best to use a grounded electrical outlet to power the amplifier. Lack of input ground reference could be unsafe. Consult with your electrical contractor about proper grounding.

Wiring Your System

1. Use direct burial wire and measure out how much you will need.
2. Dig a 6-inch deep trench to each speaker.
3. Connect the speaker wire to the speaker. It is recommended that you use heat-shrink tubing to seal each individual conductor, then heat-shrink the two connections together.

WARNING

Make sure that all connections are secure. A poor connection can lead to corrosion and a damaged speaker.

4. Run the wire through the trench to the amplifier.
5. Connect the speaker wire to the terminals on the back of your amplifier. Make sure that the speaker wires' polarity is connected correctly.
 - + (positive, red) to speaker red wire (positive)
 - (negative, black) to speaker black wire (negative)
6. Turn your amplifier on and test the system with your favorite music. If the speakers are operating properly, refill the trench.

Safety Instructions

Read & Follow:

- 1) Read these instructions in their entirety.
- 2) Store this manual and packaging in a safe place.
- 3) Heed all warnings.
- 4) Follow instructions (do not take short cuts).
- 5) Clean only with a dry cloth.
- 6) Do not block any ventilation openings. Install in accordance with the manufacturers instructions.
- 7) Do not install near any heat sources such as radiators, heat registers, stoves, or other apparatuses that produce heat.
- 8) Do not defeat the safety purpose of the polarized or grounding-type plug. A polarized plug has two blades with one wider than the other. A grounding-type plug has two blades and a third grounding prong. The wide blade or the third prong is provided for your safety. If the provided plug does not fit into your outlet, consult an electrician for replacement of the obsolete outlet.
- 9) Protect the power cord from being walked on or pinched, particularly at plugs, convenience receptacles, and the point where they exit from the apparatus.
- 10) Only use attachments & accessories specified by the manufacturer.
- 11) Unplug this apparatus during lightning storm or when unused for long period of time.
- 12) Refer all servicing to qualified service personal. Servicing is required when the apparatus has been damaged in any way such as; power-supply cord or plug is damaged, liquid has been spilled or objects have fallen into the apparatus, the apparatus has been exposed to rain or moisture, does not operate normally, or has been dropped.

Symbols Explained:



Appears on the component to indicate the presence of uninsulated, dangerous voltage inside the enclosure – voltage that may be sufficient to constitute a risk of shock.

CAUTION

Calls attention to a procedure, practice, condition or the like that, if not correctly performed or adhered to, could result in injury or death.

WARNING

Calls attention to a procedure, practice, condition or the like that, if not correctly performed or adhered to, could result in damage to or destruction of part or all of the product.

Note:

Calls attention to information that is essential to highlight.



This triangle, which appears on your component, alerts you to important operating and maintenance instructions in this accompanying literature.



One Year Limited Warranty

ROCK-on one (1) year limited warranty

Earthquake Sound warrants the original purchaser that all Factory Sealed New Audio products be free from defects in material and workmanship, under normal and proper use, for a period of one (1) year from the date of purchase (as shown on the original sales receipt with serial number affixed/written on it). The one (1) year warranty period is valid only if the product is properly installed by an Earthquake Sound authorized party, and the warranty registration card is properly filled out and sent to Earthquake Sound Corporation. If the product is installed by a non-authorized party, a thirty (30) day warranty period applies.

(A) One (1) year limited warranty guidelines:

Earthquake pays for labor, parts and ground freight (US Mainland only) back to the customer.

(B) Warning:

Products (sent for repair) that are tested by Earthquake technicians and deemed to have no problem(s) will not be covered by the limited warranty. Customer will be charged a minimum of one (1) hour of labor (at ongoing rate) plus the shipping charges back to the customer.

(C) Earthquake agrees to repair or replace - at our discretion - all such defective products/parts subject to the following provisions:

Defective products/parts have not been altered or repaired by other than an Earthquake factory approved technician.

Products/parts are not subjected to negligence, misuse, improper use, or accident, damaged by improper line voltage, used with incompatible products, or have its serial number or any part of it altered, defaced or removed, or have been used in any way that is contrary to Earthquake's written instructions.

(D) Warranty Limitations:

Earthquake warranty does not cover products that have been modified or abused, including but not limited to the following:

Damages due to misuse, abuse or use of improper cleaning materials/methods

Bent frame, broken connectors, holes/cracked in wall plate, burnt parts

Fading, deterioration of components & finish due to improper exposure to elements

Burnt tracers on PCB

Product/part damaged due to poor packaging or abusive shipping conditions

Subsequent damage to other products

A warranty claim will not be valid if the warranty registration card is not properly filled & returned to Earthquake with a copy of the sales invoice.

(E) Service Request:

To receive product(s) service, contact Earthquake Sound's service department at (510) 732-1000 or tech@earthquakesound.com and request an RMA (Return Material Authorization) number as item(s) shipped without a valid RMA number will be refused. Make sure you provide us with your complete and correct shipping address, a valid daytime phone number, and a brief description of the problem you are experiencing with the product. In most cases, our technicians might be able to resolve the problem over the phone or via e-mail, thus eliminating the need to ship the product.

(F) Shipping Instructions:

Product(s) must be packaged inside its original protective box(es) to minimize transportation damage. Shipper claims regarding items damaged in transit must be presented to carrier. Earthquake Sound Corporation reserves the right to refuse improperly packaged product(s). A copy of the original sales receipt must accompany the product(s) returned for service. Ship the product(s) to:

Earthquake Sound Corporation. 2727 McCone Avenue. Hayward, CA 94545

The customer is responsible for the cost of shipping the product(s) to Earthquake Sound Corporation

(G) Disputes Resolution:

All disputes - between clients and Earthquake Sound Corporation - resulting from the one (1) year limited warranty policy must be resolved according to the laws & regulations of the county of Alameda, California.

Owner's Notes / Comments

Purchase Date: / / .

Dealer Name:

Dealer Address:

APPLY SERIAL NUMBER



The Sound That Will *Move* You