



The Sound That Will *Move* You

PowerHouse Shredder

PHS3500.1 | PHS5000.1 | PHS8000.1



User Manual

Earthquake Sound Corporation
2727 McCone Avenue, Hayward CA, 94545. Tel: 510-732-1000
www.earthquakesound.com | www.earthquakesoundshop.com

Table Of Contents

Before You Begin	Page 3	Wiring Preparations	Page 9
End of Plate Overview	Page 4	Wiring Configurations	Page 10–12
Specifications	Page 5	Warranty	Page 12–13
Dimensions	Page 6	For Your Records	Page 14
Crossover & Gain Settings	Page 7	Notes	Page 15
Installation	Page 8		

THANK YOU

Thank you for choosing Earthquake Sound's line of PowerHouse Shredder amplifiers for superior enhancement of your mobile audio system. With proper installation and responsible listening, your amplifier(s) will give you years of near perfect sound reproduction.

We strongly recommend you to have your new amplifier(s) installed by an authorized Earthquake Sound dealer: Installation professionals employed by your dealer have the correct tools and knowledge to install your amplifier(s) neatly and successfully. Also, when your new products are installed by an authorized dealer, your product will include a ONE YEAR LIMITED WARRANTY. If you choose to perform your own installation, your warranty will be subject to limitations. Dealer policies on handling warranty requests may vary from one dealer to the next. Please read the warranty information in its entirety and use good judgment when making these vital decisions. Earthquake sound will not be held responsible for any improper handling or installation of its products.

CAUTION:

Earthquake Sound audio products are capable of generating high sound pressure levels. You should exercise caution when operating these amplifier systems. Long term exposure to high levels of sound pressure can cause permanent damage to your hearing. Sound pressure levels exceeding 85dB can be dangerous with constant exposure. Set your audio system to a comfortable loudness level. Earthquake Sound Corporation does not assume liability for damages resulting from the direct use of its audio products and urges users to play volume at moderate listening levels.

SOUND LEVEL dBA	DURATION PER DAY (HOURS)
90	8
92	6
95	4
97	3
100	2
102	1–1 1/2
105	1
110	1/2
115	1/4 or less

This chart shows the U.S. Government's occupational safety and health administration (OSHA) regulations which were in effect at the time if this publication for permissible noise exposure per 29CFR1910.95, table G-16.

BEFORE YOU BEGIN

THE RIGHT POWER SUPPLY

To ensure normal operation, adequate power must be available to drive your vehicle's electronic equipment, both car components and car accessories.

When designing electrical systems, most manufactures do not accommodate for the power demands of high performance audio components. Such components increase the load placed on the vehicle's electrical system. It is imperative to balance the power needs of audio components with what your vehicle's electrical system can produce.

Upgrading your vehicle's electrical system is most crucial to the success of high power audio systems. When upgrading a vehicle's electrical system, consider the following:

A. HIGH OUTPUT ALTERNATORS

High output alternators are available from car audio dealers and auto parts stores. These products are sold complete with installation kits. High output alternators allow faster charging of the batteries and more energy for your vehicle's audio system.

B. REGULATORS

Regulators are designed to maintain the output voltage of alternators at one level or set-point. Low set-point will not allow for faster charging. High set-point might damage your vehicle's electrical system. Earthquake recommends that you consult with a qualified auto technician for level setting.

C. BATTERIES

Batteries are your power storage tanks. Adding a second battery will increase the amount of listening time especially when your vehicle is off. The most preferred method of connecting two batteries to the vehicle charging system is to use a two-way battery isolator.

D. DUAL BATTERY ISOLATORS

Isolators are available in car audio and automotive stores and most car accessory stores. Prices are very affordable and units are sold complete with application instructions.

E. STIFFENING CAPACITORS

Stiffening capacitors are capable of delivering lots of energy in very short amounts of time. A stiffening capacitor installed in parallel with the battery stabilizes the current and provides the instant energy demanded by high power amplifiers.

END OF PLATE OVERVIEW

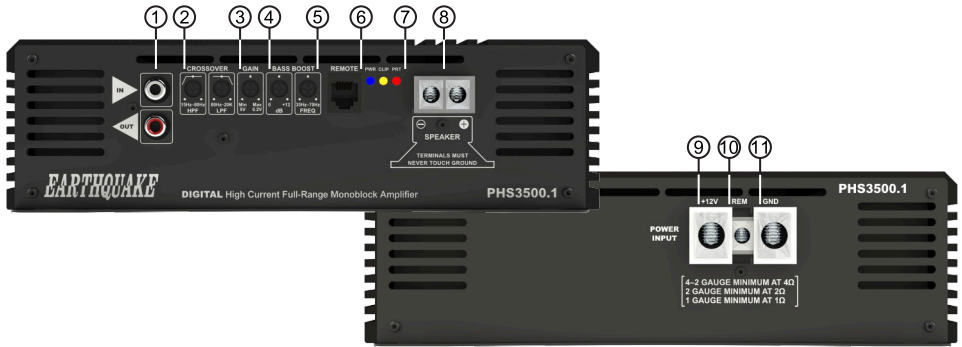

- 1. RCA INPUT & OUTPUT:** Low level input and output with range of 0.2V to 5V RMS. Be sure to use a high low level adapter if your vehicle does not have a subwoofer output.
- 2. Crossover:** The high pass filter (HPF) is used to filter out unwanted low frequencies from 15Hz–80Hz and the low pass filter (LPF) is used to filter out unwanted mid and high frequencies from 80Hz–20kHz.
- 3. GAIN CONTROL:** The gain control is used to regulate the amplifier's sensitivity to match the signal output voltage of the audio source/head unit. Note that this is not a volume control. Always start at the MIN position and slowly increase the gain. Stop as soon as distortion is heard and then lower the gain until distortion disappears and only clear sound is produced.
- 4. BASS BOOST:** Boosts the chosen center frequency from 0 to +12dB.
- 5. FREQUENCY ADJUST:** Used to adjust the boosted center frequency.
- 6. REMOTE SUB LEVEL:** This is used to adjust the amplifier's bass output from a location of your choice. A typical location for the remote install is somewhere on the dash of your vehicle that makes it easily accessible.
- 7. LED INDICATORS:** There are three LED indicator lights that show the working status of the amplifier. Blue indicates that the amp is powered on and functioning properly. Orange indicates that the input signal of the amp is overpowered. Refer to the gain settings. Red indicates that the amp is on protection mode due to improper installation or internal damage done to the amp.
- 8. SPEAKER WIRE OUTPUTS:** These amplifiers feature set screw-down style speaker wire output connectors.
- 9. +12V BATTERY TERMINAL:** This screw-down style terminal is used to connect the amplifier to the vehicle's battery positive (+) using the specified wire gauge size shown underneath the terminal block.
- 10. REMOTE TERMINAL:** This screw-down style terminal is used to connect a remote cable from the amplifier to the remote terminal of the head unit.
- 11. GROUND TERMINALS:** This screw-down style terminal is used to connect the amplifier to the vehicle's chassis/ground using a short 4-gauge wire (2 feet maximum in length).

SPECIFICATIONS

	PHS3500.1	PHS5000.1	PHS8000.1
Amp Class	D	D	D
Channels	1	1	1
PWR Out 1Ω	4000 WRMS @ 1% THD	5500 WRMS @ 1% THD	9000 WRMS @ 1% THD
PWR Out 2Ω	2700 WRMS @ 1% THD	3500 WRMS @ 1% THD	5800 WRMS @ 1% THD
PWR Out 4Ω	1700 WRMS @ 1% THD	1850 WRMS @ 1% THD	3300 WRMS @ 1% THD
HPF	15Hz-80Hz	15Hz-80Hz	15Hz-80Hz
LPF	80Hz-2kHz	80Hz-2kHz	80Hz-2kHz
Boost level	0-12dB	0-12dB	0-12dB
Bass Boost Frequency	35Hz-70Hz	35Hz-70Hz	35Hz-70Hz
Mono In	Yes	Yes	Yes
Mono Out	Yes	Yes	Yes
S/C Protection	Yes	Yes	Yes
Fuse Rating	4-Ohm 100A 2-Ohm 150A 1-Ohm 200A	4-Ohm 150A 2-Ohm 175A 1-Ohm 250A	4-Ohm 200A 2-Ohm 350A 1-Ohm 400A
Min Wire Gauge Sizes	4-Ohm 4-2 Gauge 2-Ohm 2 Gauge 1-Ohm 1 Gauge	4-Ohm 4-2 Gauge 2-Ohm 2 Gauge 1-Ohm 1 Gauge	4-Ohm 4-2 Gauge 2-Ohm 2 Gauge 1-Ohm 1 Gauge

LED Indicators	Blue = Power Orange = Clip Red = Protection
-----------------------	---

DIMENSIONS

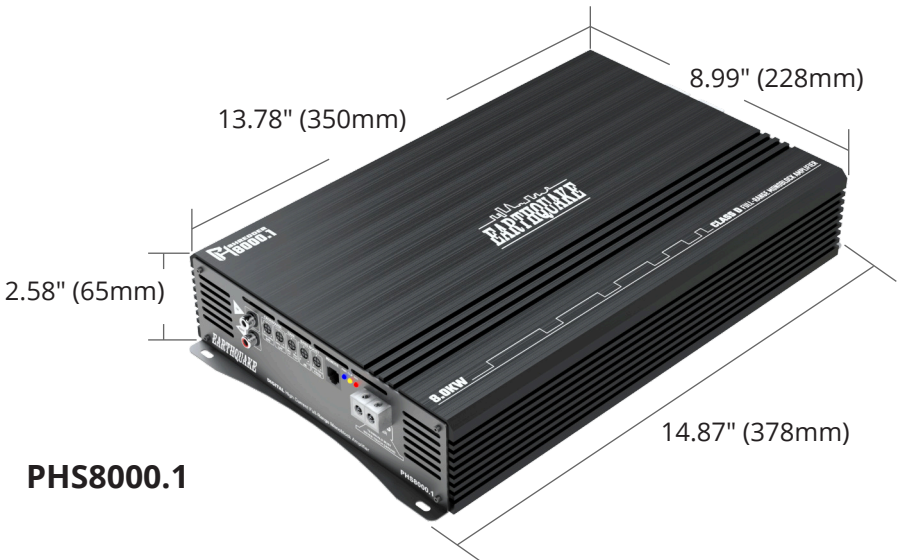
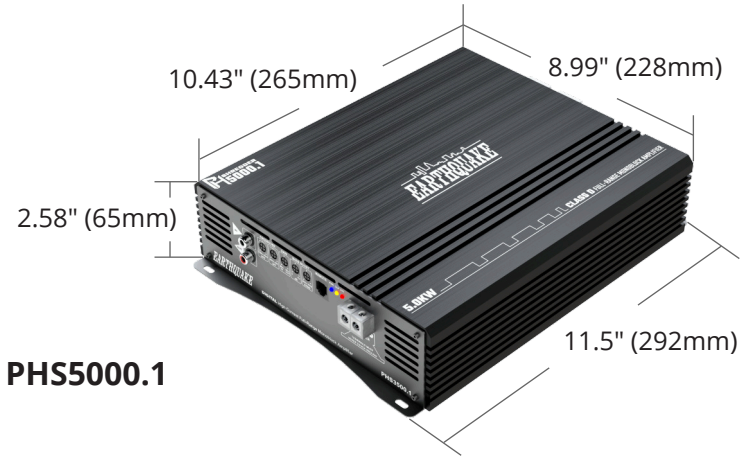
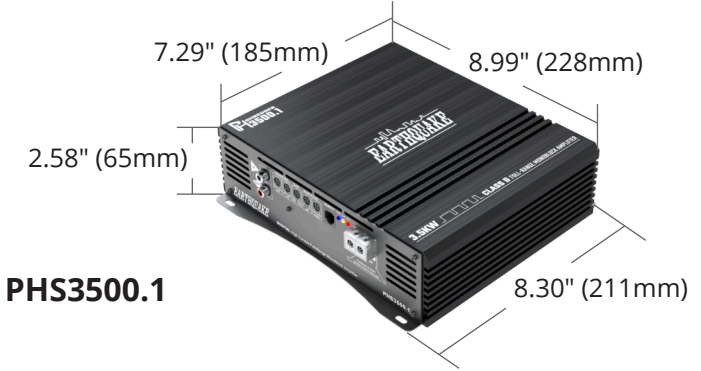

CROSSOVER & GAIN SETTINGS (ALL MODELS)

HPF CROSSOVER SETTINGS

HPF KNOB SETTING					
CROSSOVER SETTING POINT	15Hz	30Hz	40Hz	60Hz	80Hz

LPF CROSSOVER SETTINGS

LPF KNOB SETTING					
CROSSOVER SETTING POINT	80Hz	500Hz	8kHz	15kHz	20kHz

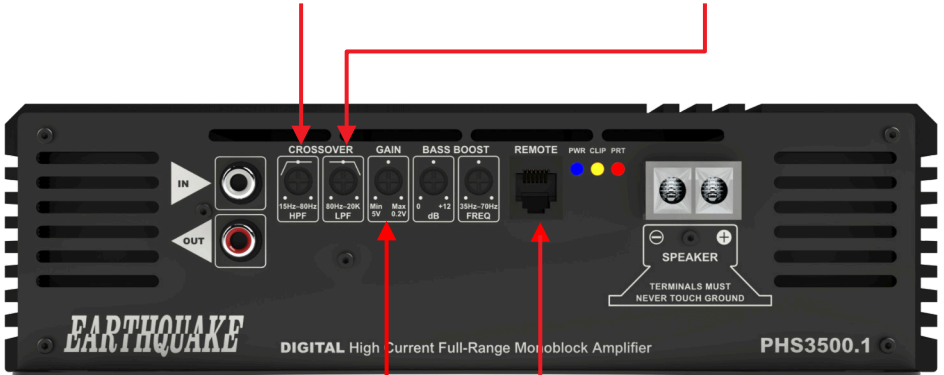

GAIN SETTINGS

GAIN KNOB SETTING		
MAX OUTPUT VOLTAGE BEFORE CLIP	5V	0.2V

Remote Gain Control: Allows for the amp input sensitivity control from the dashboard or other remote points.

- To Battery (+)
- To Remote turn on / Trigger
- To Car Chassis / Ground

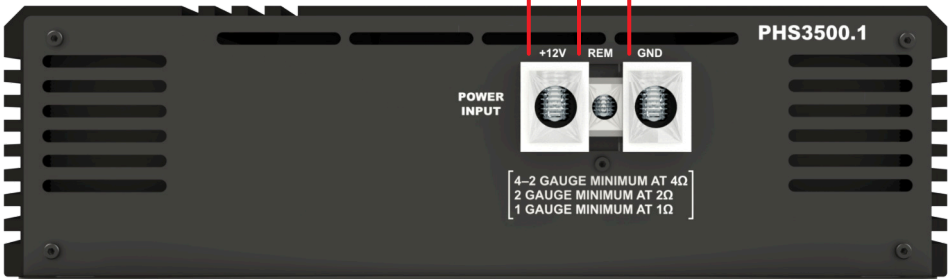

INSTALLATION

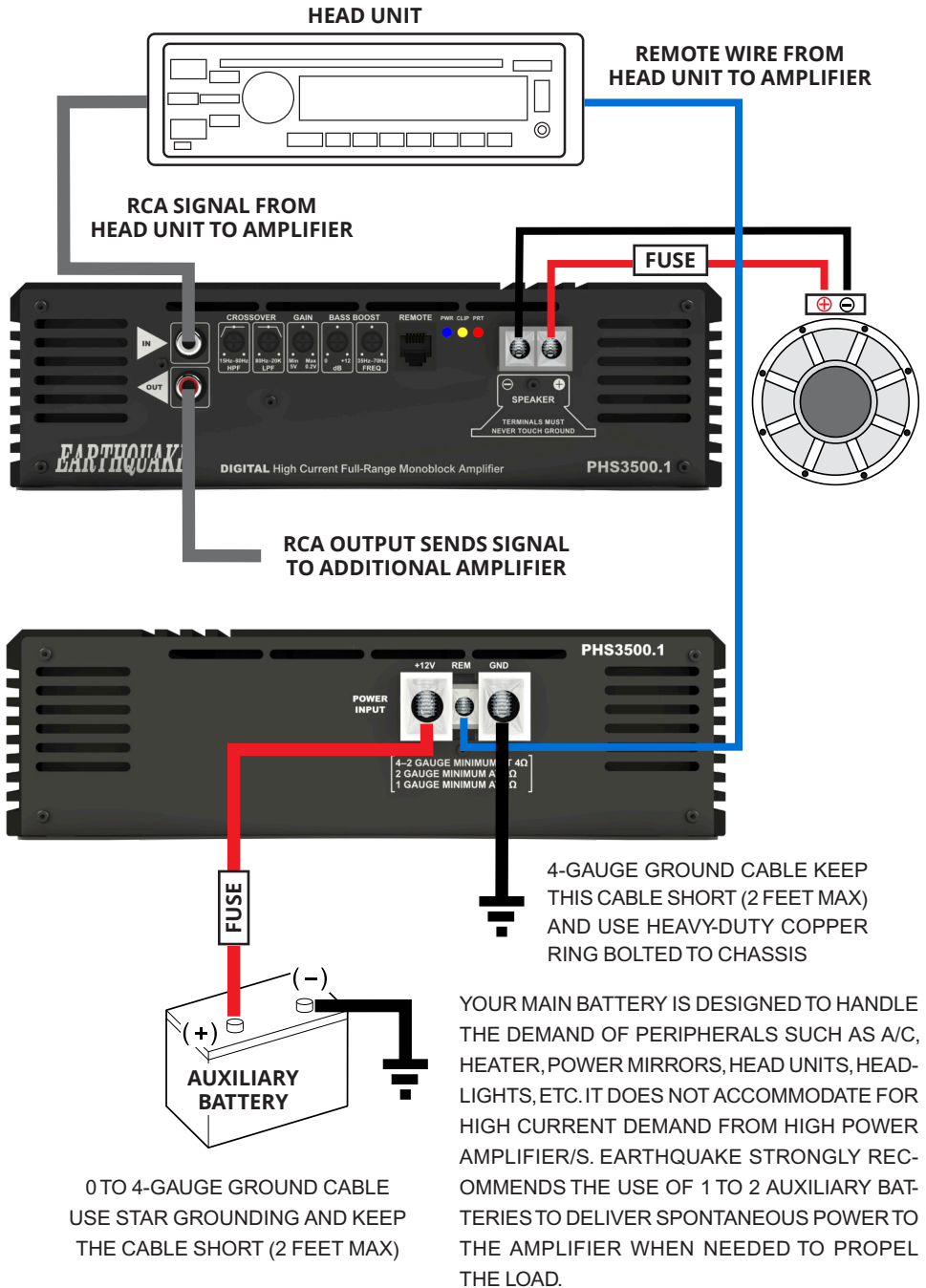

WIRING PREPARATIONS

- ☑ Test the alternator output. Factory alternators will produce 60 to 80 amperes at best. Wear and heat will reduce the output by 40%.
- ☑ Alternator ground (-) must be reinforced, use 4-gauge cable instead of the factory 8-gauge.
- ☑ Alternator positive (+) to battery (+) must be reinforced. Use 4-gauge cables.
- ☑ Check your battery condition. Batteries degrade after a while.
- ☑ Battery (+) to amplifier (+) , must be a 4-gauge cable.
- ☑ Ground amplifier to chassis using 4-gauge cable, keep the cable short (maximum 2-feet).
- ☑ Use 1 farad capacitor to compensate for surges in demand.
- ☑ We recommend the use of 1 to 2 auxiliary batteries depending on 1, 2, or 4-Ohm loads.

WARNING: Make sure that the amplifier is completely off and not connected to any power source during the wiring process. Failure to do so may result in a short that will damage the amplifier or cause bodily harm or injuries.

Take note of the following prior to installation:

1. You must confirm that your power supply can deliver spontaneous power to the amplifier when needed to propel the load.
2. Bulletproof ground: The ground cable must be 4-gauge minimum and also very short and well attached to the chassis.

WIRING CONFIGURATIONS

One Single 2-Ohm Subwoofer (1-Ohm Minimum)

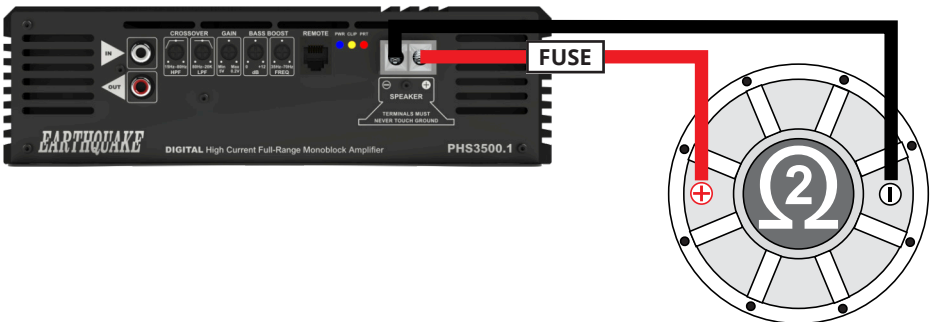

WIRING CONFIGURATIONS CONT.

Single Dual 4-Ohm Subwoofer (1-Ohm Minimum)

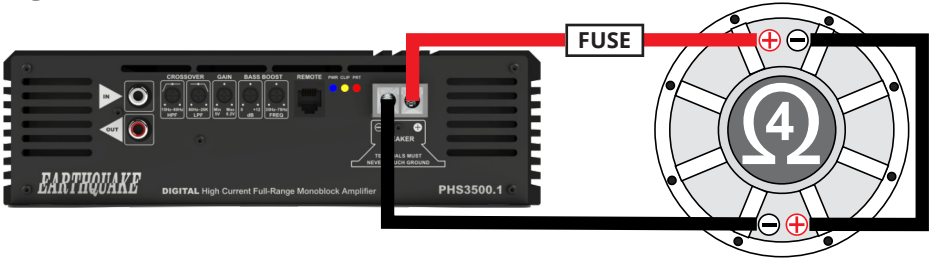

Two Dual 4-Ohm Subwoofers 1-Ohm

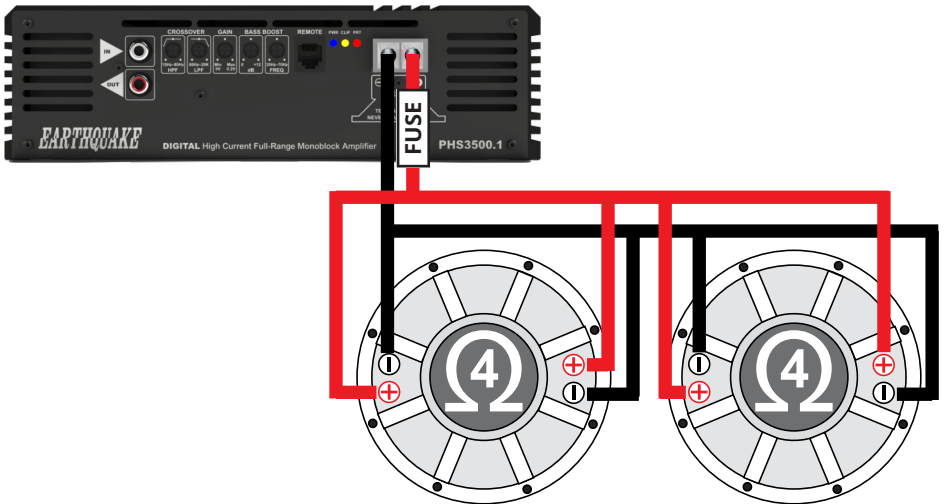

WIRING CONFIGURATIONS CONT.

Two Single 4-Ohm Subwoofers 2-Ohm

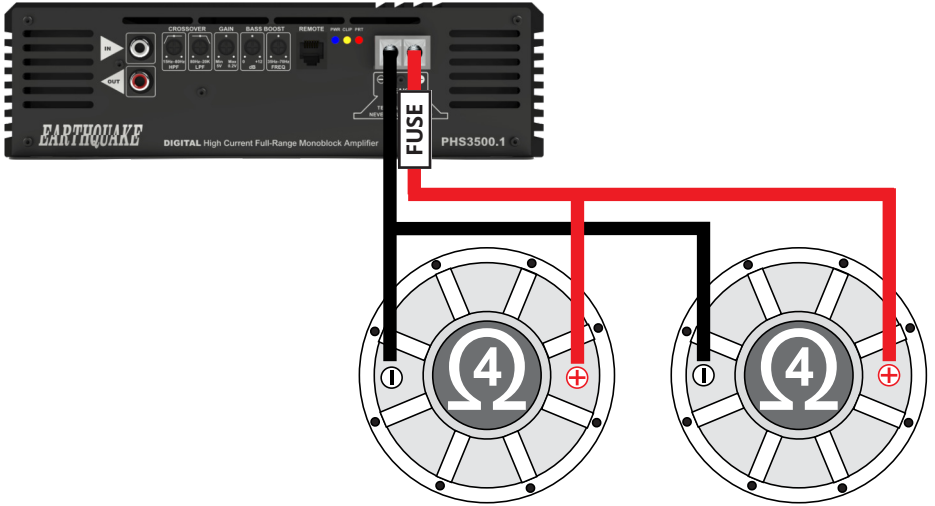

SENDING SIGNAL TO ADDITIONAL AMPLIFIER/S

Rear of typical head unit with subwoofer RCA outputs

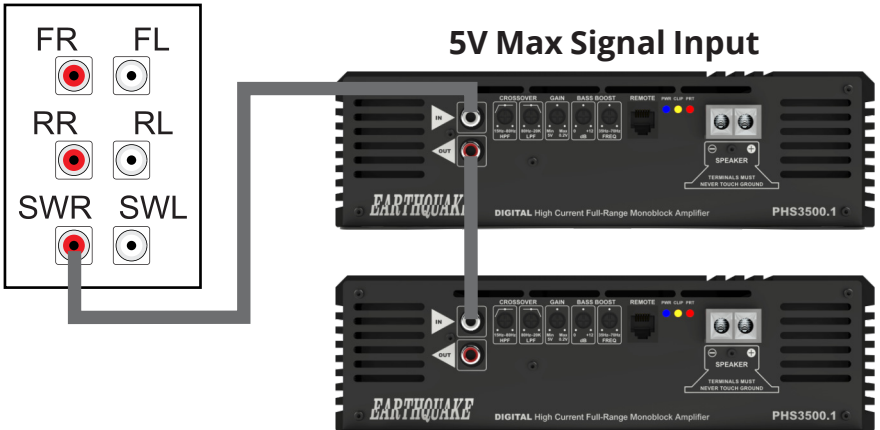

1 YEAR LIMITED WARRANTY INFORMATION

Earthquake Sound warrants the original purchaser that all Factory Sealed New Audio products be free from defects in material and workmanship, under normal and proper use, for a period of **one (1) year from the date of purchase** (as shown on the original sales receipt with serial number affixed/written on it). The one (1) year warranty period is valid only if the product is properly installed by an Earthquake Sound authorized party and the warranty registration card is properly filled out and sent to Earthquake Sound Corporation. If the product is installed by a non-authorized party, a thirty (30) day warranty period applies.

(A) One (1) year limited warranty guidelines:

Earthquake pays for labor, parts, and ground freight (US Mainland only, not including Alaska and Hawaii) back to the customer. Shipping to us is not covered.

(B) Warning:

- Products (sent for repair) that are tested by Earthquake technicians and deemed to have no problem(s) will not be covered by the limited warranty. Customer will be charged a minimum of one (1) hour of labor (at ongoing rate) plus the shipping charges back to the customer.
- Each product sent in for repair must be packaged in its original packaging. Otherwise, **repackaging charges will apply in addition to the labor, parts, and shipping charges.**

(C) Earthquake agrees to repair or replace - at our discretion - all such defective products/parts subject to the following provisions:

- Defective products/parts have not been altered or repaired by other than an Earthquake factory approved technician.
- Products/parts are not subjected to negligence, misuse, accident, or damaged by improper line voltage.
- Products/parts were used with incompatible products.
- The serial number or any part of the product has been altered, defaced, or removed.
- Products/parts have been used in any way that is contrary to Earthquake's written instructions.

(D) Warranty Limitations:

Earthquake warranty does not cover products that have been modified or abused, including but not limited to the following:

- Damages due to misuse, abuse or use of improper cleaning materials/methods.
- Bent speaker frame, broken connectors, hole(s) in speaker cone, hole(s) in surround or dust cap, and burnt speaker voice coil.
- Fading and/or deterioration of speaker components & finish due to improper exposure to elements.
- Burnt tracers on PCB.
- Product/part damaged due to poor packaging or abusive shipping conditions.
- Subsequent damage to other products.

A warranty claim will not be valid if the warranty registration card is not properly filled & returned to Earthquake with a copy of the sales invoice.

WARRANTY INFORMATION CONT.

(E) Service Request:

To receive product(s) service, contact Earthquake Sound's service department at (510) 732-1000 or tech@earthquakesound.com and request an RMA (Return Material Authorization) number as item(s) shipped without a valid RMA number will be refused. Make sure you provide us with your complete and correct shipping address, a valid daytime phone number, and a brief description of the problem you are experiencing with the product. In most cases, our technicians might be able to resolve the problem over the phone or via e-mail, thus eliminating the need to ship the product.

(F) Shipping Instructions:

Product(s) must be packaged inside its original protective box(es) to minimize transportation damage. Shipper claims regarding items damaged in transit must be presented to carrier. Earthquake Sound Corporation reserves the right to refuse improperly packaged product(s). A copy of the original sales receipt must accompany the product(s) returned for service. Ship the product(s) to:

Earthquake Sound Corporation. 2727 McCone Avenue. Hayward, CA 94545

The customer is responsible for the cost of shipping the product(s) to Earthquake Sound Corporation

(G) Disputes Resolution:

All disputes - between clients and Earthquake Sound Corporation - resulting from the one (1) year limited warranty policy must be resolved according to the laws & regulations of the county of Alameda, California.

FOR YOUR RECORDS

We strongly suggest keeping a copy of your sales receipt and note the model and serial number of your product here for future reference.

Model No.

PHS _ _ _ _ .1

For technical support, please contact:

E-mail: tech@earthquakesound.com

Phone: 510-732-1000

Serial No.

Date of Purchase MM/DD/YYYY



The Sound That Will *Move* You

Earthquake Sound reserves the right to amend details of the specifications without notice.

Copyright © Earthquake Sound Corporation

Earthquake Sound Corporation

2727 McCone Avenue, Hayward CA, 94545 • Phone: 510-732-1000

www.earthquakesound.com • www.earthquakesoundshop.com