

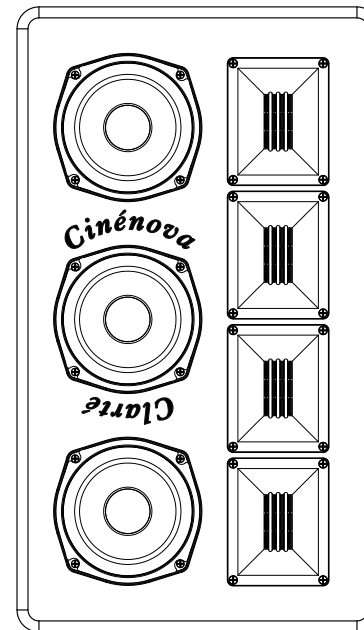

The Sound That Will Move You

# *Cinénova Clarté*

In-Wall & On-Wall  
LCR Speaker



OW-C5

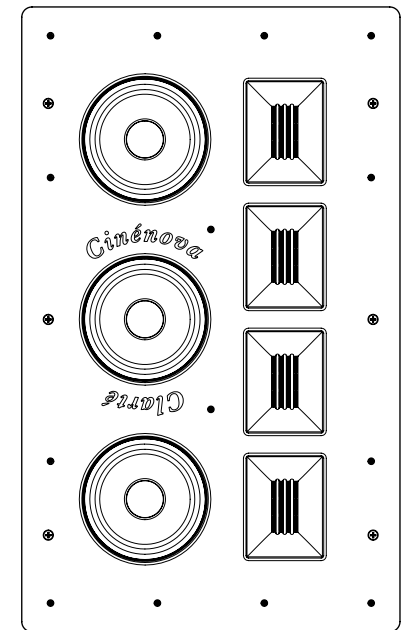

IW-C5



The Sound That Will Move You

## Table of Contents

Introduction.....	3
In-Wall Overview.....	4
On-Wall Overview.....	5
In-Wall Specifications.....	6
On-Wall Specifications.....	7
Home Theater Setup.....	8
Speaker Placement.....	9
Speaker Placement Cont.....	10
In-Wall Installation.....	11
On-Wall Installation.....	12
Warranty Guidelines.....	13
Notes.....	14–15

## Notes

Earthquake Sound Corporation  
2727 McCone Ave. Hayward,  
CA 94545. USA  
Tel: 510-732-1000  
Fax: 510-732-1095



© 2021 Earthquake Sound Corporation. All rights reserved.

This document should not be construed as a commitment on the part of Earthquake Sound Corporation. The information is subject to change without notice. Earthquake Sound Corporation assumes no responsibility for errors that may appear within this document.

The Cinénova Clarté on-wall and in-wall LCR are Earthquake’s newest addition to the infamous Cinénova family of high fidelity products. The Clarté was designed to be mounted vertically or horizontally allowing it to be positioned for left, right, and center channels. This offers plenty of flexibility whether you are installing them for new or pre-existing home audio setups. Both the on-wall and in-wall Clarté speakers feature a combination of three 5.25" glass fiber cone woofers for distortion-free bass and four 2" ultra-fast ribbon tweeters for remarkable sound quality with pinpoint accuracy. With Earthquake’s Cinénova Clarté LCR, you will hear more details in music and movies with elegant sound reproduction and tonal balance.

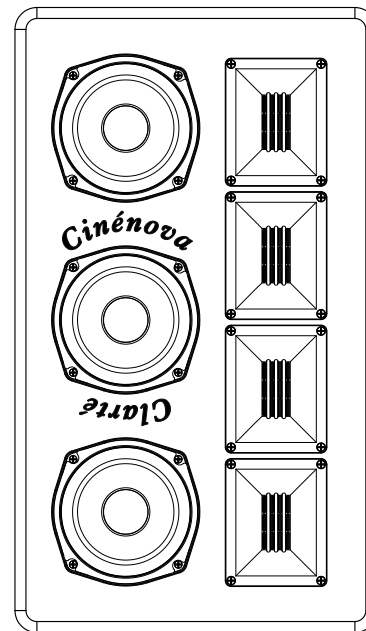

**On-Wall  
(OW-C5)**

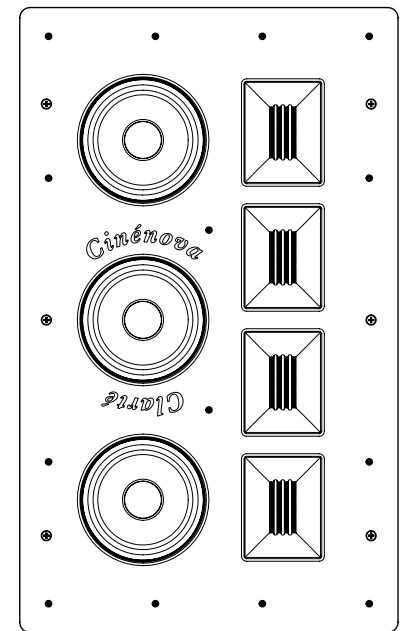

**In-Wall  
(IW-C5)**

## In-Wall Overview

1. 5.25" glass fiber cone woofers
2. 2" ribbon tweeters
3. Gold plated spring loaded terminals
4. Cross style mounting bracket
5. Center wiring groove
6. Wall/cabinet bushing
7. Turn-N-Lock™ mechanism (x6)
8. Turn-N-Lock screw (x6)

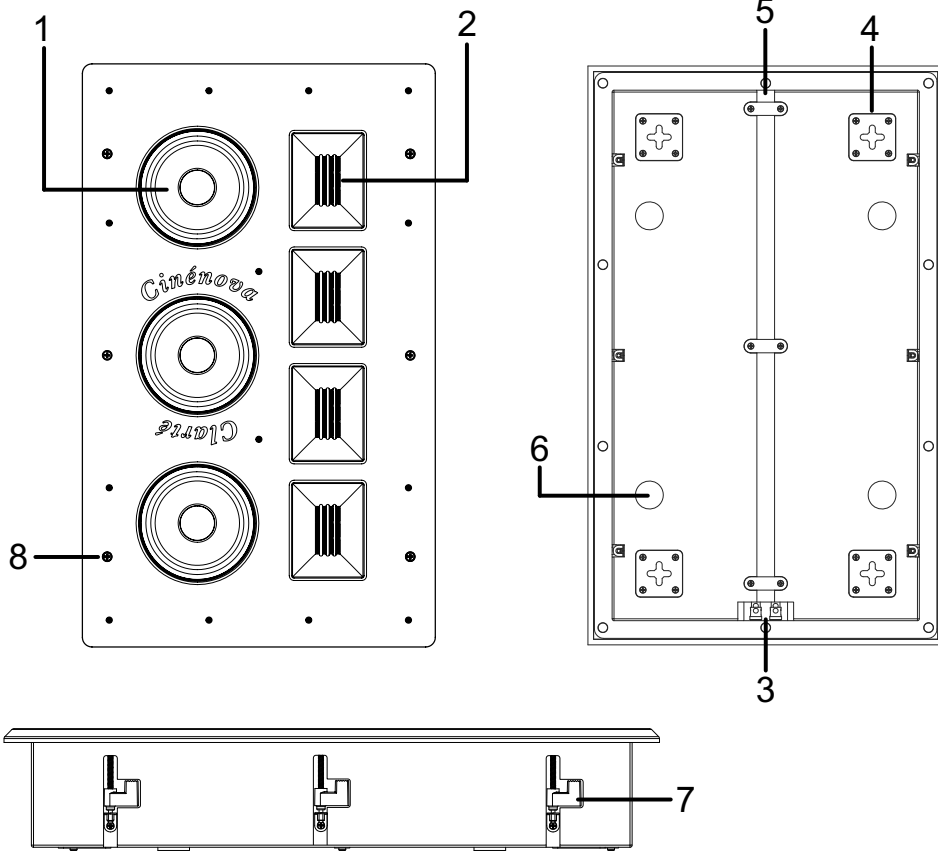

## Warranty

Earthquake Sound warrants the original purchaser that all Factory Sealed New Audio products be free from defects in material and workmanship, under normal and proper use, for a period of one (1) year from the date of purchase (as shown on the original sales receipt with serial number affixed/written on it). The one (1) year warranty period is valid only if the product is properly installed by an Earthquake Sound authorized party and the warranty registration card is properly filled out and sent to Earthquake Sound Corporation. If the product is installed by a non-authorized party, a thirty (30) day warranty period applies.

### (A) One (1) year limited warranty guidelines:

- Earthquake pays for labor, parts and ground freight (US Mainland only) back to the customer.

### (B) Warning:

Products (sent for repair) that are tested by Earthquake technicians and deemed to have no problem(s) will not be covered by the limited warranty. Customer will be charged a minimum of one (1) hour of labor (at ongoing rate) plus the shipping charges back to the customer.

### (C) Earthquake agrees to repair or replace - at our discretion - all such defective products/parts subject to the following provisions:

- Defective products/parts have not been altered or repaired by other than an Earthquake factory approved technician.
- Products/parts are not subjected to negligence, misuse, improper use, or accident, damaged by improper line voltage, used with incompatible products, or have its serial number or any part of it altered, defaced or removed, or have been used in any way that is contrary to Earthquake's written instructions.

### (D) Warranty Limitations:

Earthquake warranty does not cover products that have been modified or abused, including but not limited to the following:

- Damages due to misuse, abuse or use of improper cleaning materials/methods.
- Bent frame, broken connectors, holes in speaker cone, holes/cracked in wall plate, burnt parts.
- Fading, deterioration of components & finish due to improper exposure to elements.
- Burnt tracers on PCB.
- Product/part damaged due to poor packaging or abusive shipping conditions.
- Subsequent damage to other products.

A warranty claim will not be valid if the warranty registration card is not properly filled & returned to Earthquake with a copy of the sales invoice.

### (E) Service Request:

To receive product(s) service, contact Earthquake Sound's service department at (510) 732-1000 or [tech@earthquakesound.com](mailto:tech@earthquakesound.com) and request an RMA (Return Material Authorization) number as item(s) shipped without a valid RMA number will be refused. Make sure you provide us with your complete and correct shipping address, a valid daytime phone number, and a brief description of the problem you are experiencing with the product. In most cases, our technicians might be able to resolve the problem over the phone or via e-mail, thus eliminating the need to ship the product.

### (F) Shipping Instructions:

Product(s) must be packaged inside its original protective box(es) to minimize transportation damage. Shipper claims regarding items damaged in transit must be presented to carrier. Earthquake Sound Corporation reserves the right to refuse improperly packaged product(s). A copy of the original sales receipt must accompany the product(s) returned for service. Ship the product(s) to:

Earthquake Sound Corporation, 2727 McCone Avenue, Hayward, CA 94545

The customer is responsible for the cost of shipping the product(s) to Earthquake Sound Corporation

### (G) Disputes Resolution:

All disputes - between clients and Earthquake Sound Corporation - resulting from the one (1) year limited warranty policy must be resolved according to the laws & regulations of the county of Alameda, California.

## On-Wall Installation

Use the built-in cross mounting brackets to mount the on-wall Clarté. The speaker weighs over 20lbs and should be mounted to either a wall stud using M4 sized screws (not included) or spring loaded toggle bolts if not mounted to a stud. The mounting hardware can be found at most local hardware stores.

Horizontal Installation

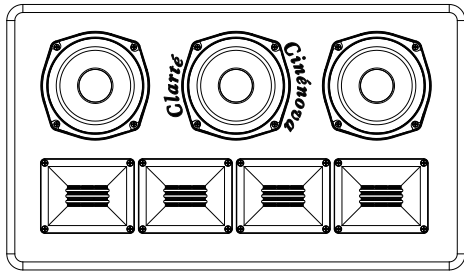

Vertical Installation

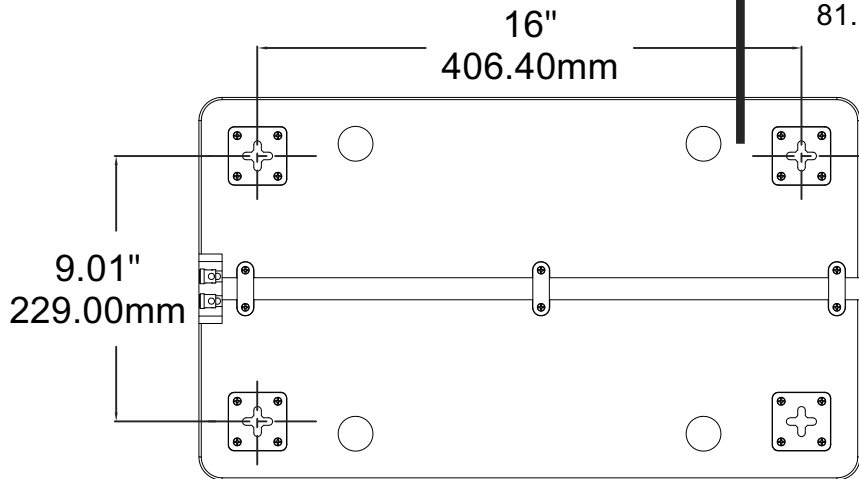
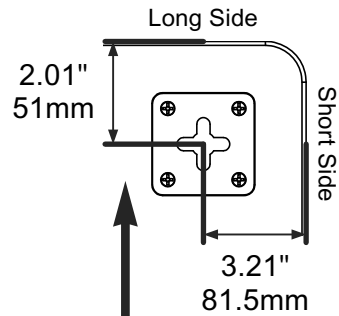
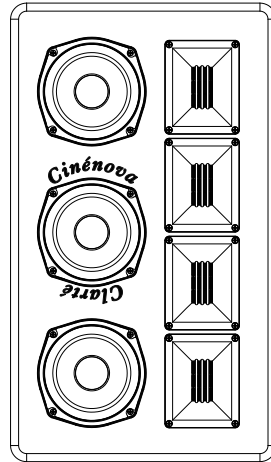

Use the dimensions above for mounting the OW-C5 to the wall. For added convenience, the mounting brackets are spaced apart 16 inches on center when the OW-C5 is placed in a horizontal position.

## On-Wall Overview

1. 5.25" glass fiber cone woofers
2. 2" ribbon tweeters
3. Gold plated spring loaded terminals
4. Cross style mounting bracket
5. Center wiring groove
6. Wall/cabinet bushing

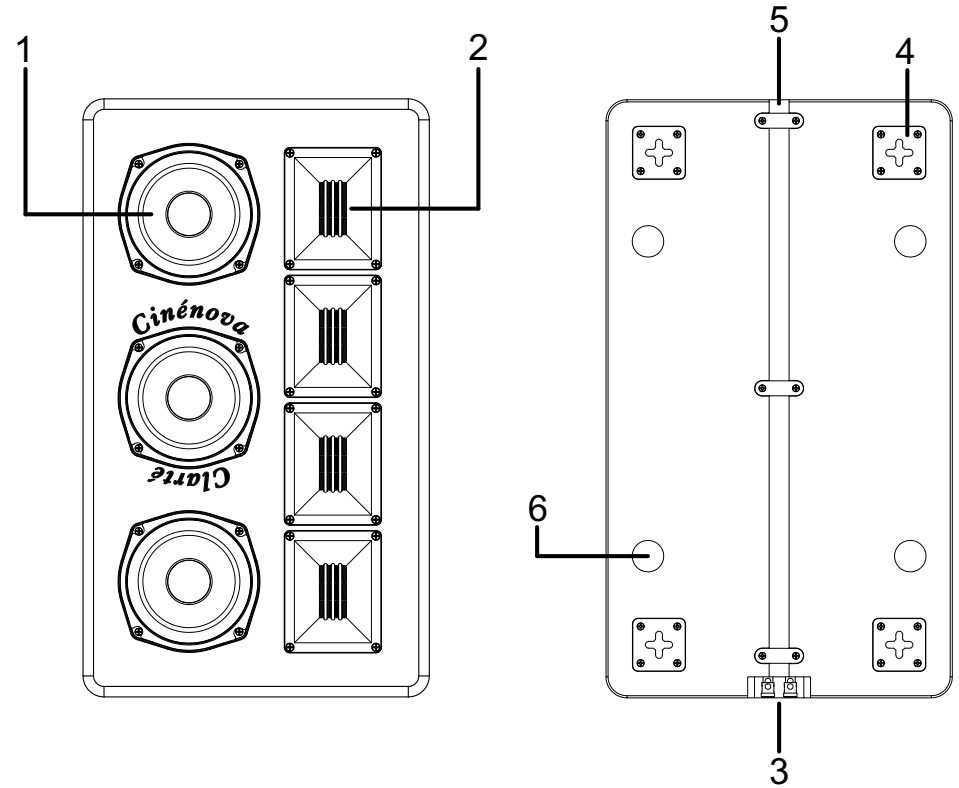

## In-Wall Specifications

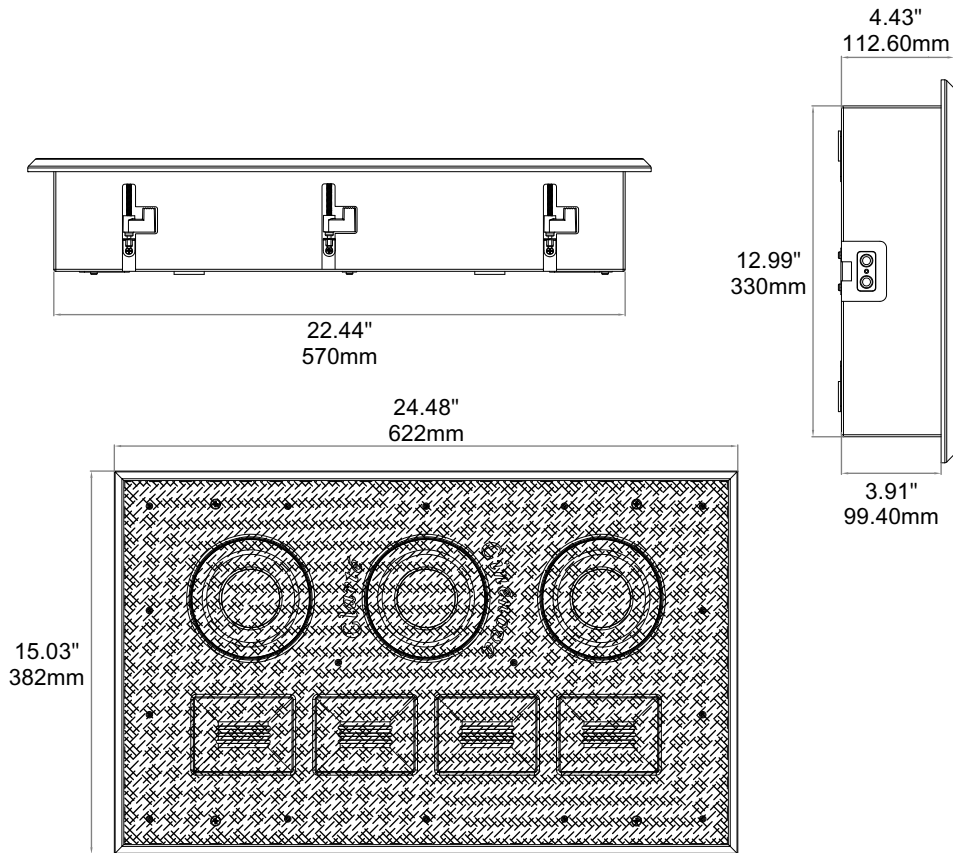

15.03"  
382mm

IW-C5	
Power Handling	120 WRMS 600 Watts Max
Frequency Response	40Hz–20kHz
Crossover Frequency	2000Hz LP 12dB/Oct 2000Hz HP 12dB/Oct
Coverage Angles	122 Vertical 122 Horizontal
Impedance	8-Ohm
SPL	96dB ± 3dB
Weight	23.58 lbs (10.70 kgs)
Mounting Depth	3.91" (99.40mm)

## In-Wall Installation

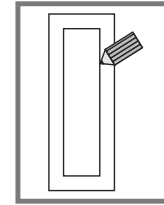

### LOCATE & MARK STUDS

Outline the cut out hole using the supplied template. Stay clear from any 2 x 4 studs.

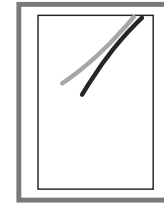

### CUT THE DRYWALL

Cut out the drywall marked by the supplied template.

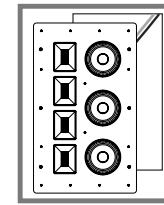

### CONNECT THE SPEAKER

Attach speaker wires and insert the Clarté speaker into the dry-wall opening.

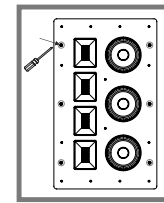

### SECURE WITH TURN-N-LOCK™

Align the speaker into position. Tighten the screws evenly to secure the unit with the TURN-N-LOCK™ mechanism. Turning the screws clockwise will engage the mechanism. Keep turning the screw until the TURN-N-LOCK™ dog ear moves towards the front plate and is snug against the inside of the drywall. This will ensure that the speaker is firmly secure inside of the wall.

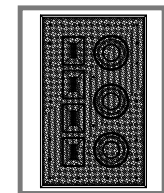

### PLACE THE GRILLE

Align the speaker grille into position. The grille will magnetically attach itself to the plate.



Cutout template included

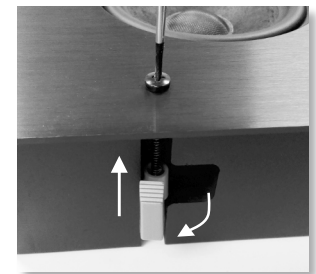
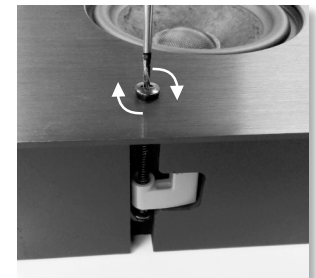

## Speaker Placement Cont.

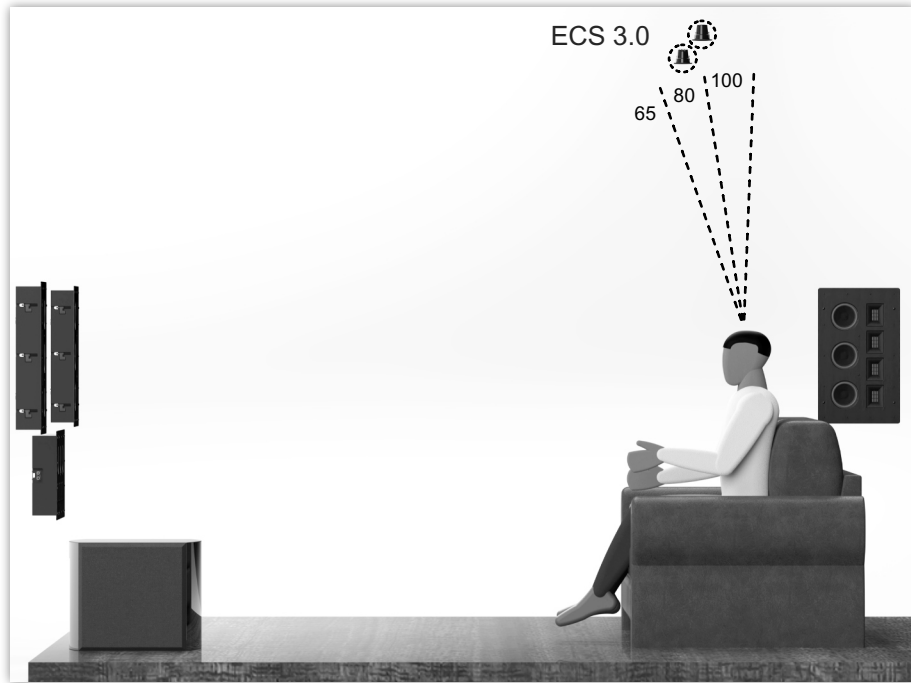

## On-Wall Specifications

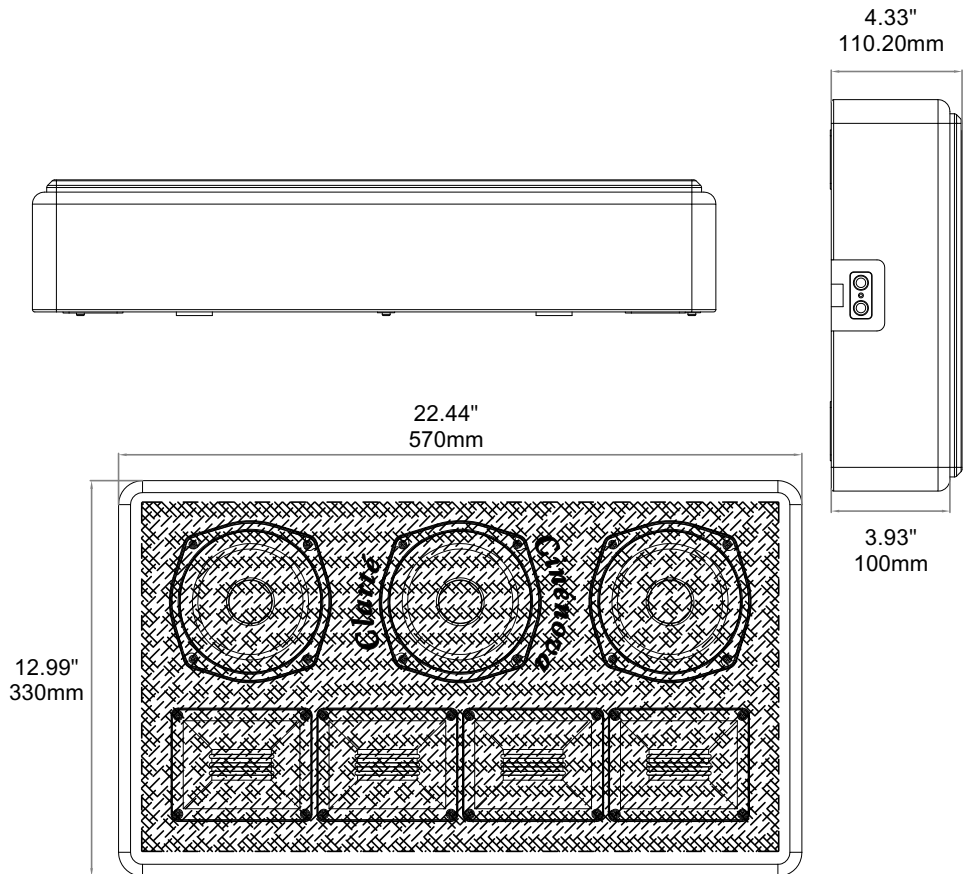

OW-C5	
Power Handling	120 WRMS 600 Watts Max
Frequency Response	40Hz-20kHz
Crossover Frequency	2000Hz LP 12dB/Oct 2000Hz HP 12dB/Oct
Coverage Angles	122 Vertical
	122 Horizontal
Impedance	8-Ohm
SPL	96dB ± 3dB
Weight	20.95 lbs (9.50 kgs)

## Home Theater Setup

Home Theater LCR Setup  
With MiniMe DSP Subwoofer

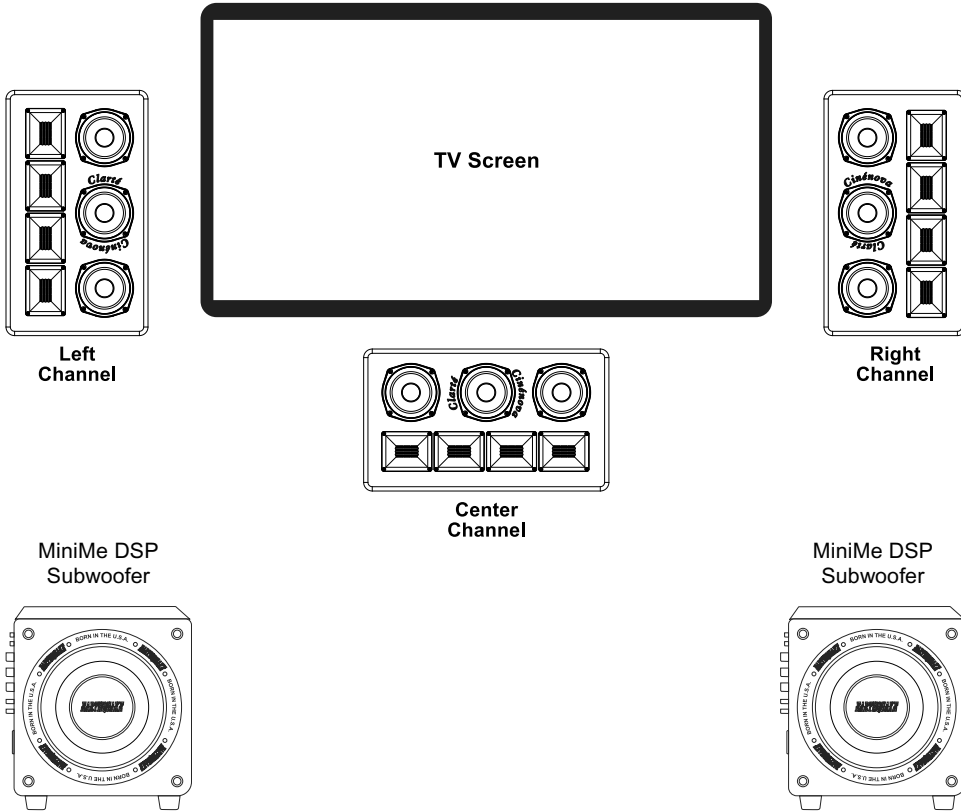

The illustration above demonstrates how the on-wall and in-wall Clarté can be positioned for a typical left, right, and center channel home theater setup. Note that the units should be positioned so that the tweeters are on the outside.

## Speaker Placement

The Cinénova Clarté speakers were designed to be mounted either on or flush with the walls depending on the model. To optimize their acoustics you should follow these simple guidelines.

For the best stereo reproduction, the speakers should be placed an equal distance from your listening position and separated so that the angle between them is between 40 and 60°. The units should also be placed with the tweeters on the outside and near ear level about 3 to 4 feet from the floor. This will ensure that you receive the best possible performance from your listening position..

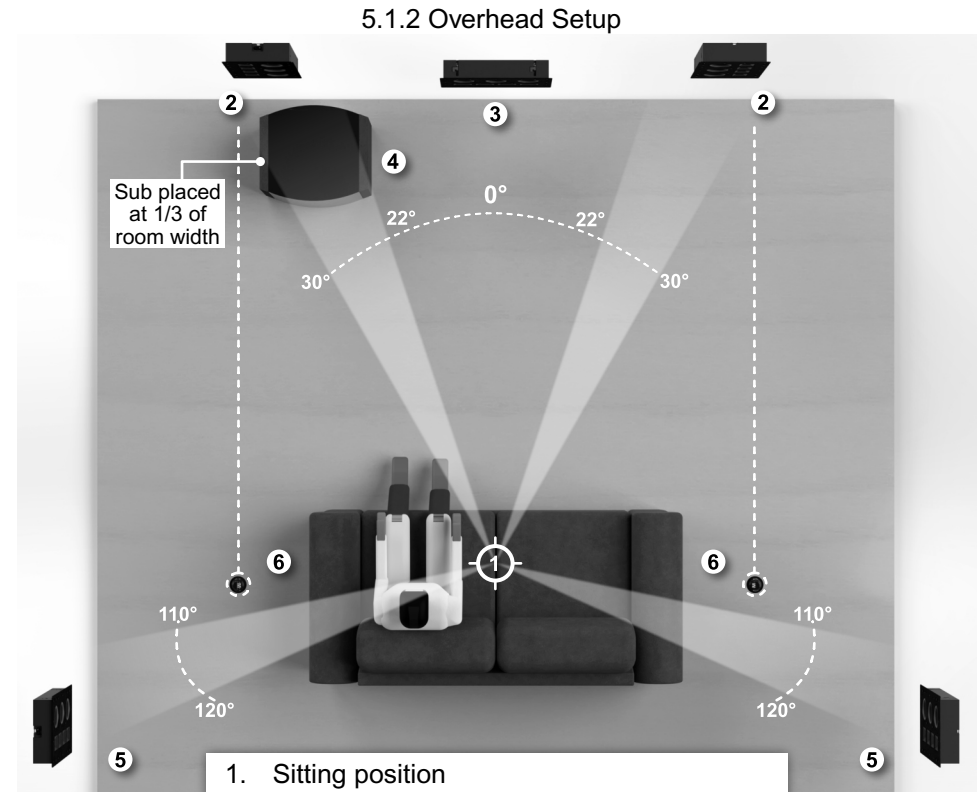

1. Sitting position
2. Front left and right Cinénova Clarté
3. Center Cinénova Clarté
4. Supernova MKVII subwoofer
5. Surround left and right Cinénova Clarté
6. Overhead Left and right ECS 3.0