

# *Nova*

*Power From The Heavens*

↓

## **Nova FF6.5 Front Firing Powered Subwoofers Operation Manual & Technical Guide**



# FF6.5 Front Firing Subwoofer

## Table of Contents

Introduction .....	2
Warranty Guideline .....	3
Specifications & Performance .....	4
Product Overview .....	5
Control Panel Overview .....	6
Subwoofer Placement .....	6
Connecting Your Subwoofer .....	7

## Dear Valued Customer,

Welcome to the eclectic world of Earthquake High Fidelity sound systems; you are about to experience the FF6.5 subwoofer. This system is designed to dramatically enhance your enjoyment of music and films at home, by adding power and impact to low frequency sound effects.

Earthquake Sound Corporation is located in the heart of the Silicon Valley. It specializes in manufacturing high end home and car audio products ranging from the smallest driver to the loudest subwoofer system. In its dedication to excellence, Earthquake has maintained extensive programs in research and development to provide you with the highest quality audio products.

This owners manual is designed to better acquaint you with the Nova FF6.5 subwoofer system and guide you through the phases of system design and application. It is imperative that you read this manual in its entirety. Simply call 1-800-576-7944 for EARTHQUAKE technicians and staff to answer any questions you might have in regards to the FF6.5 subwoofer.



A handwritten signature in cursive script that reads "Joseph Sahyoun".

*Professor Joseph J. Sahyoun  
President & Chief Engineer*



**WARNING:** This product is capable of generating high sound pressure levels. You should exercise caution when operating these speakers. Long term exposures to high levels of sound pressure will cause permanent

damage to your hearing. Sound pressure levels exceeding 85dB can be dangerous with constant exposure, set your audio system to a comfortable loudness level. Earthquake Sound Corporation does not assume liability for damages resulting from the direct use of Earthquake subwoofers, and urges users to play volume at moderate levels.

## **Five (5) Years Limited Warranty.**

Earthquake warrants the original purchaser that all Factory Sealed New Audio Products to be free from defects in material and workmanship under normal and proper use for a period of five (5) years from the date of purchase (as shown on the original original sales receipt with serial number affixed/written on it).

The five (5) year warranty period is valid only if an authorized Earthquake dealer properly installs the product and the warranty registration card is properly filled out and sent to Earthquake Sound Corporation. If a non-authorized party installs the product, a ninety (90) day warranty period will be applied.

### **(A) Five (5) years limited warranty plan coverage guidelines:**

- **First year:** Earthquake pays for labor, parts, and ground freight (only in US mainland, not including Alaska and Hawaii. Shipping to us is not covered).
- **Second, third, fourth & fifth year:** Earthquake pays labor only. Customer must pay for parts and freight both ways.

### **(B) Warning:**

Products (sent for repair) that are tested by Earthquake technicians and deemed to have no problem(s) will not be covered by the five (5) year limited warranty. Customer will be charged a minimum of one (1) hour of labor (at the ongoing rates) plus shipping charges back to customer.

### **(C) Earthquake will repair or replace at our option all defective products/parts subject to the following provisions:**

- Defective products/parts have not been altered or repaired by other than an Earthquake factory-approved technicians.
- Products/parts are not subjected to negligence, misuse, improper use or accident, damaged by improper line voltage, used with incompatible products or have its serial number or any part of it altered, defaced or removed, or have been used in any way that is contrary to Earthquake's written instructions.

### **(D) Warranty Limitations:**

Warranty does not cover products that have been modified or abused, including but not limited to the following:

- Damages to speaker cabinet and cabinet finish due to misuse, abuse or improper use of cleaning materials/methods.
- Bent speaker frame, broken speaker connectors, holes in speaker cone, surround & dust cap, burnt speaker voice coil.
- Fading and/or deterioration of speaker components & finish due to improper exposure to elements.
- Bent amplifier casing, damaged finish on the casing due to abuse, misuse or improper use of cleaning material.
- Burnt tracers on PCB.
- Product/part damaged due to poor packaging or abusive shipping conditions.
- Subsequent damage to other products.

**A** warranty claim will not be valid if the warranty registration card is not properly filled & returned to Earthquake with a copy of the sales receipt.

### **(E) Service Request:**

To receive product service, contact Earthquake Service Department at (510) 732-1000 and request an RMA number (Return Material Authorization). Items shipped without a valid RMA number will be refused. Make sure you provide us with your complete/correct shipping address, a valid phone number, and a brief description of the problem you are experiencing with the product. In most cases, our technicians might be able to resolve the problem over the phone, thus eliminating the need to ship the product.

### **(F) Shipping Instructions:**

Product(s) must be packaged in its original protective box(es) to minimize transport damage and prevent repackaging cost (at the ongoing rates). Shipper claims regarding items damaged in transit must be presented to carrier. Earthquake Sound Corporation reserves the right to refuse improperly packed product. Original bill of sale must accompany product returned to service. We encourage you to include with the package a written description of the problem. Ship product to:

Earthquake Sound Corp.  
2727 McCone Avenue, Hayward, CA 94545.  
Tel: (510) 732-1000.

You are responsible for the cost of shipping the product to Earthquake Sound Corporation.

### **(G) Disputes Resolution:**

All disputes between clients and Earthquake Sound Corporation resulting from the five (5) year limited warranty policy must be resolved according to the laws & registration of the county of Alameda California.

## **PRODUCT REGISTRATION**

This Earthquake product can be registered by returning the Product Registration card attached to this manual. Please also retain sales receipt, which represents proof of purchase.

# Specifications & Performance

## Specifications

**Power:** 150 watts

**Frequency Response:** 28-180Hz

### Dimensions

Height: 9-15/16" (252.4mm) - including 3/8" (10.4mm) legs

Width: 7-11/16" (194mm)

Depth: 14-1/4" (361mm) - including amplifier controls

**Weight:** 16.5 lbs / 7.5 kgs

**Power Line Voltage:** 115-230~AC / 50/60Hz

**Output Levels:** Greater than 100dB peak SPL (includes room gain) from 40Hz to 135Hz.

## Performance

Typical Near Field Measurements

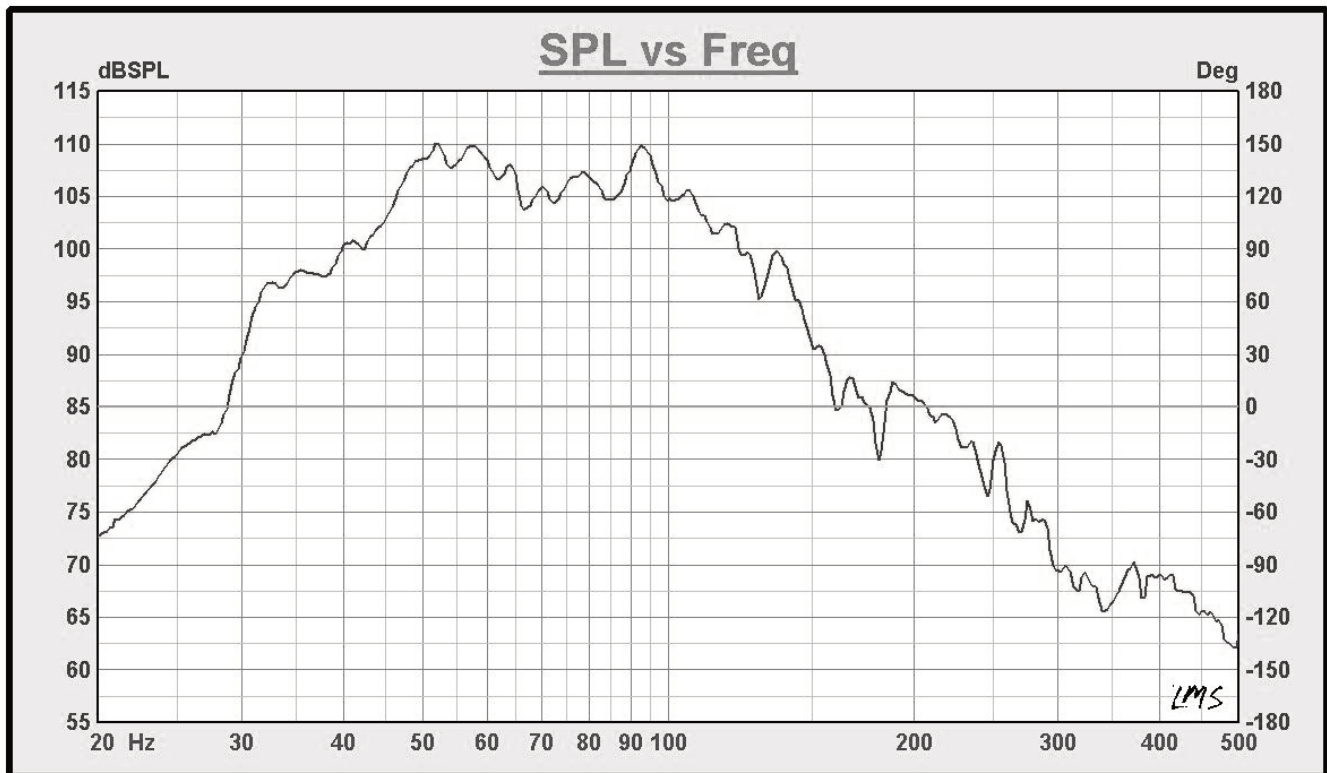

# Product Overview

## Class "A/B" Amp

150 Watts Class "A/B" high efficiency power amplifier

12 dB/Octave variable filter from 40Hz–180Hz

Automatic signal detection circuitry. When set to "AUTO", the amplifier automatically turns on when an audio signal is detected. The amplifier will also go into a standby mode after 30 minutes if no signal is detected

Low level (RCA) audio inputs

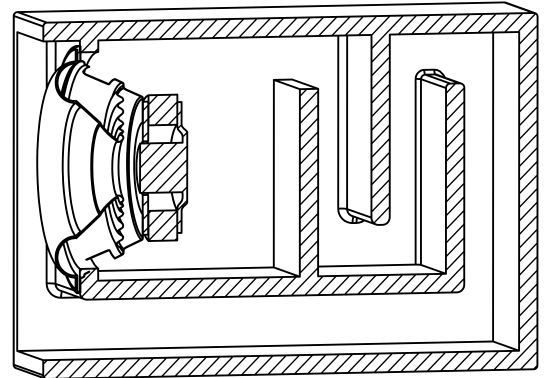

**FF6.5 Transmission Line Design**

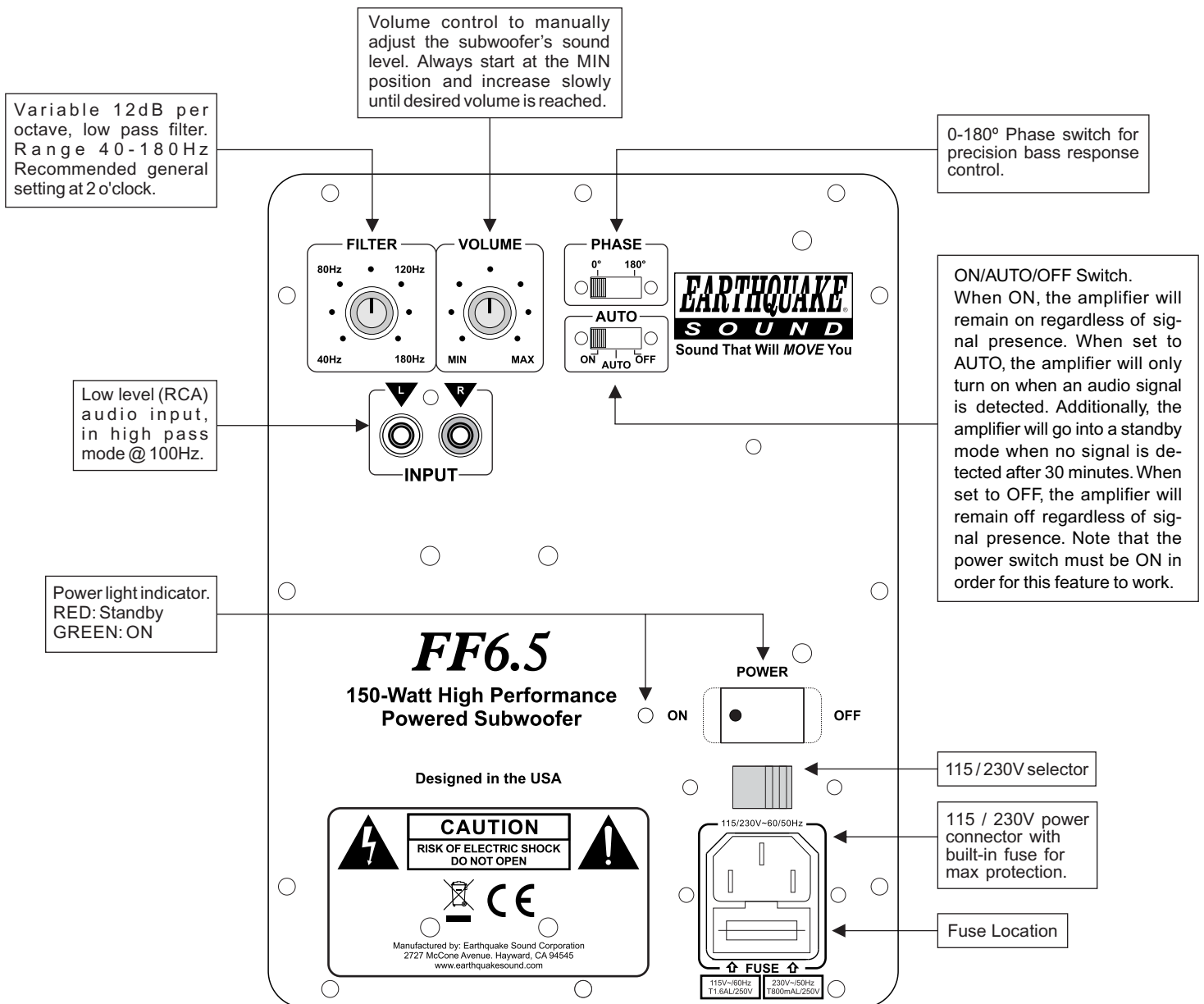

# Positioning Your Subwoofer

## Subwoofer Placement

There is no argument among audio professionals that the loudest bass output from a subwoofer comes from corner placement. The sound flaring outward from a room corner focuses low frequencies giving them no place to go but toward you. In the case of subwoofers, there is no automatic penalty in giving overall balance for this peak bass, since your main speakers can be located elsewhere. It still may be too much bass for your room or (more particularly) your favorite listening spot in the room, but unless you are seated in a "void" spot, where sound from the sub is cancelled or diminished by out-of-phase reflections from elsewhere, there should be plenty of bass from corner placement.

If you are seated in such a void spot, your only real choices are to move either the subwoofer or your listening position until the bass returns to the point that satisfies your listening criteria. Turning up the level control or changing the crossover point almost certainly won't help much. But flipping the phase control 180 degrees sometimes may make a difference, especially if the void is a product of cancellations caused by interaction with low frequencies from your main speakers.

## Using Two Subwoofers

If you choose the use two woofers, the sound output will double (an increase of 5dB). Locate the woofers with one in each corner and experiment with the location and phase control to achieve the best bass response.

Always drive each woofer through the Left/Mono input even though you are driving one woofer on a right channel drive and the other with a left channel drive. If your pre-amplifier has a single Sub/LFE output, use a 'Y' cable to split it into two outputs.

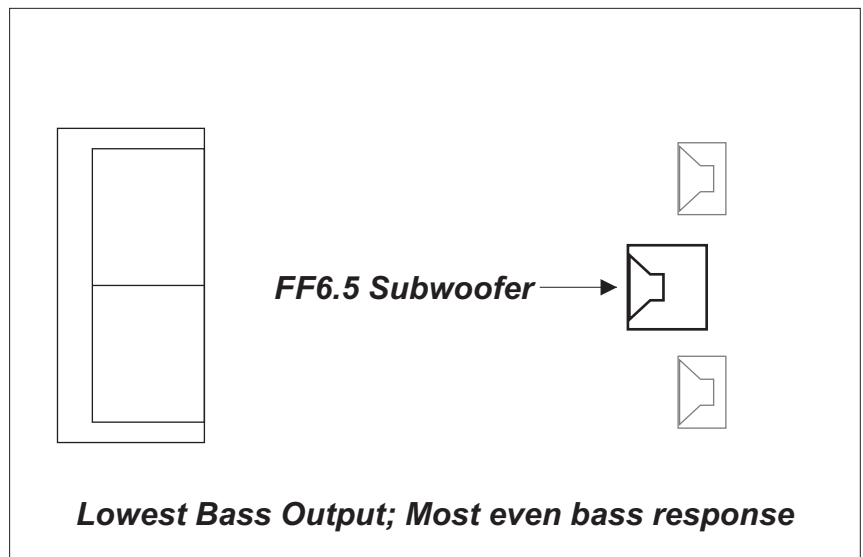
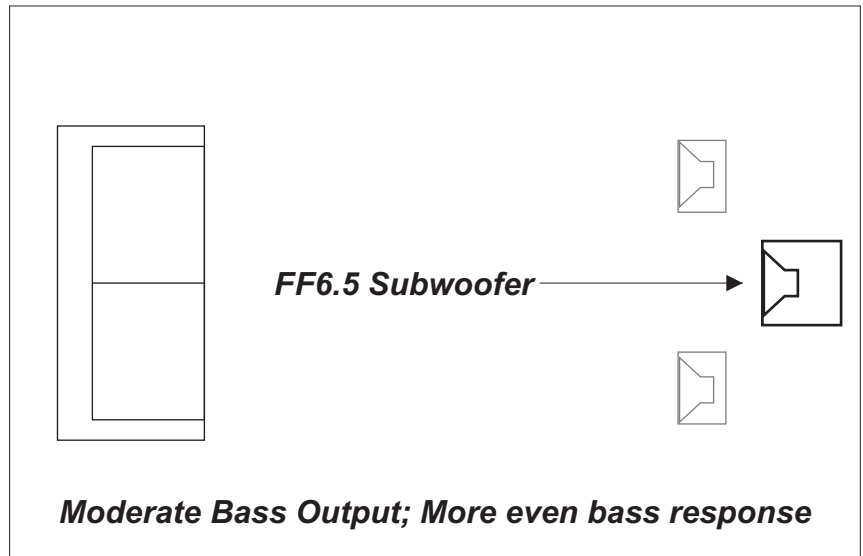
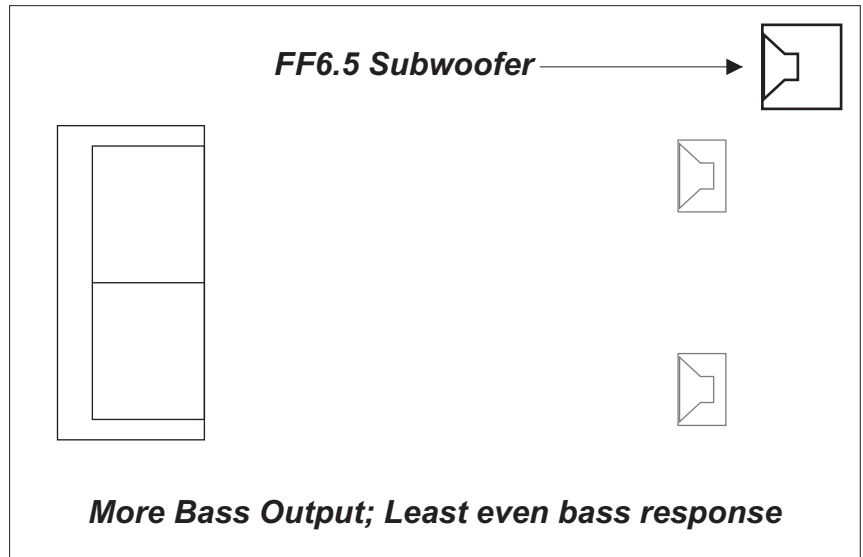

# Connecting Your Subwoofer

## Low Level (RCA) Input Connection

1. Locate the LINE IN RCA on the FF6.5 amplifier.
2. Connect the FF6.5 to the signal source, i.e. AV receiver. Even though there is no need to have both RCAs to the signal source since the subwoofer is often operated in mono signal, we recommend connecting the receiver to both RCA inputs in order to obtain higher signal level.
3. If needed, connect the LINE OUT RCA to another amplifier to drive satellite speakers (front or rear). The LINE OUT RCA has high pass filtered signal at about 70Hz (5dB/Octave cut off).

FF6.5 Amplifier  
Plate

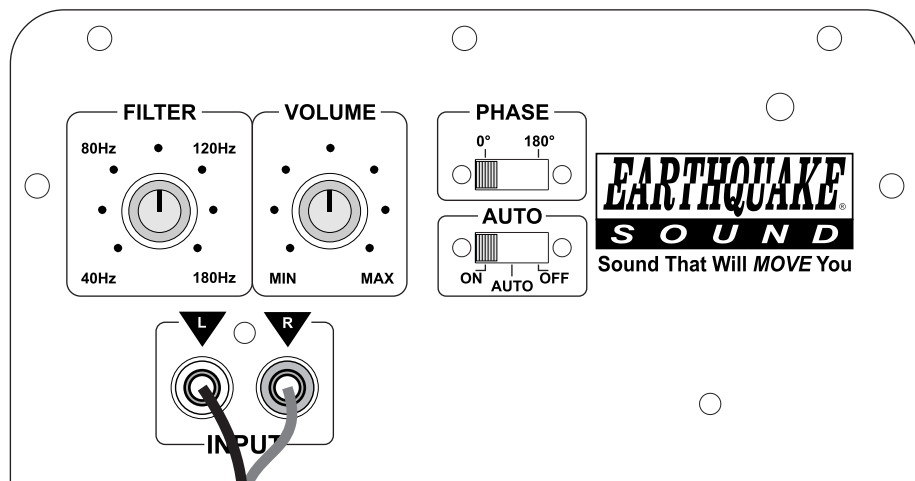

Amplifier or  
Receiver

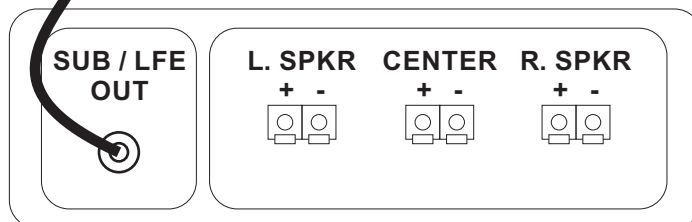



*Sound That Will Move You.*

**2727 McCone Avenue. Hayward, CA 94545. USA**  
**US Toll Free: 1-800-576-7944 | Tel: 1-510-732-1000 | Fax: 1-510-732-1095**  
**[www.earthquakesound.com](http://www.earthquakesound.com)**